



MODEL 204 SWIVEL ASSEMBLY

MAJOR SERVICE INSTRUCTIONS

1. After swivel assembly has been removed from its mounting plate and separated from boom, remove snap ring with an appropriate snap ring pliers.



2. With the help of a vise ...

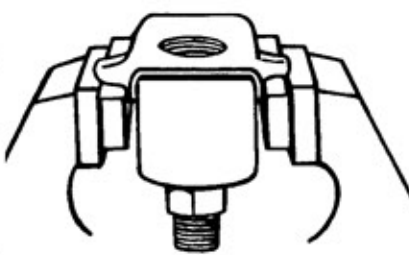

3. ... or two blocks of wood, invert the swivel assembly and rest it on the vise jaws or wood blocks. Make sure there is a minimum of 1 1/4" below spindle for removal.

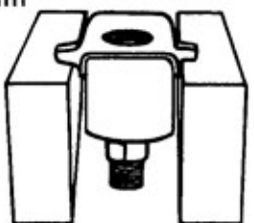

4. Insert a piece of aluminum, brass, or wood dowel (between 11/16" and 13/16" in diameter) into the threaded hole and against the internal shoulder.



5. With a hammer, tap the dowel so as to drive the bearings and spindle assembly from its housing. Severely corroded units may require somewhat harder blows to free.



Note:
Be careful not to nick the internal sides of the 7/8" diameter hole in the spindle. This is a sealing surface. Scratches and nicks could result in leaking when put into service.

6. With the help of an arbor press or vise, place a soft piece of aluminum or brass on the threaded end of the spindle. Make sure the bearing is supported on its inner race.



7. Lightly drive the spindle through the bearing. Be careful not to damage the spindle since it is made of stainless steel and should last forever.



8. With a piece of sand-paper remove any rust or other deposits from the inside of the bearing housing.

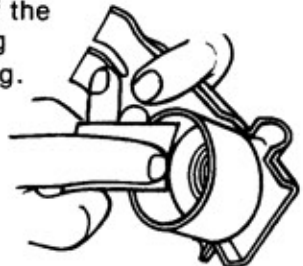

9. Check snap ring groove for cleanliness and sharp corners (a groove with rounded corners should be discarded).

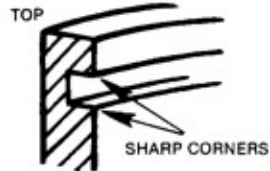

TOP
SHARP CORNERS

10. Inspect the inside diameter of spindle for nicks or scratches. Fine sand-paper will remove any possible buildups or minute scratches. (spindles with nicks or gouges should be discarded).



11. With the use of an arbor press or vise, install a new bearing onto spindle.

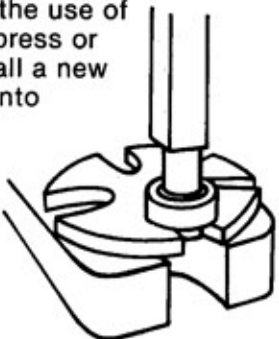

MODEL 204 MAJOR SERVICE INSTRUCTIONS (continued)

12. The bearings may be put on any way, however, press the bearing on far enough so that the inner race will rest firmly on the shoulder of the spindle.

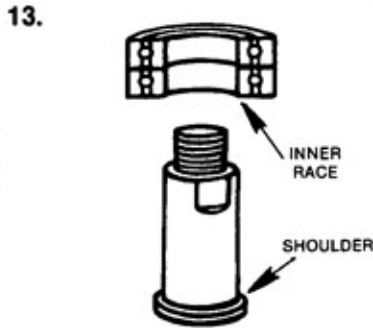

14. Place new bearings and spindle assembly into bearing housing.



15. If inside of housing is clean and the bearings started straight, the bearing and spindle assembly should just slip in. If not, the use of a tube to push on the bearings outer race will ease installation.

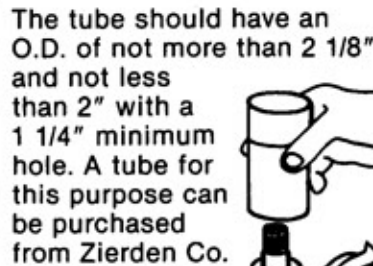

16. Lightly tap the bearing and spindle assembly into the housing if it does not slide in by hand.



17. Place the bearing retaining ring over the spindle and on the bearing, raised side up.



18. Replace the snap ring.



CAUTION:

The snap ring must be seated properly in its groove or the boom will separate from the swivel when pressure is applied, causing possible property damage and personal injury.

CAUTION:

Check that the snap ring is seated by tapping the ring with a punch all around its perimeter — lightly.

19. The unit is now ready for final assembly to boom.

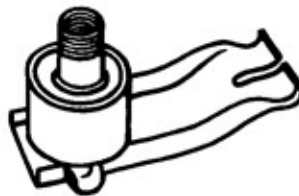

THE ZIERDEN COMPANY

7355 SOUTH 1st STREET • OAK CREEK, WISCONSIN 53154 • PHONE (414) 764-6630 • FAX (414) 764-9763

www.zierden.com