

Owner's Manual

This Manual Must Be Read Before Operating The Equipment

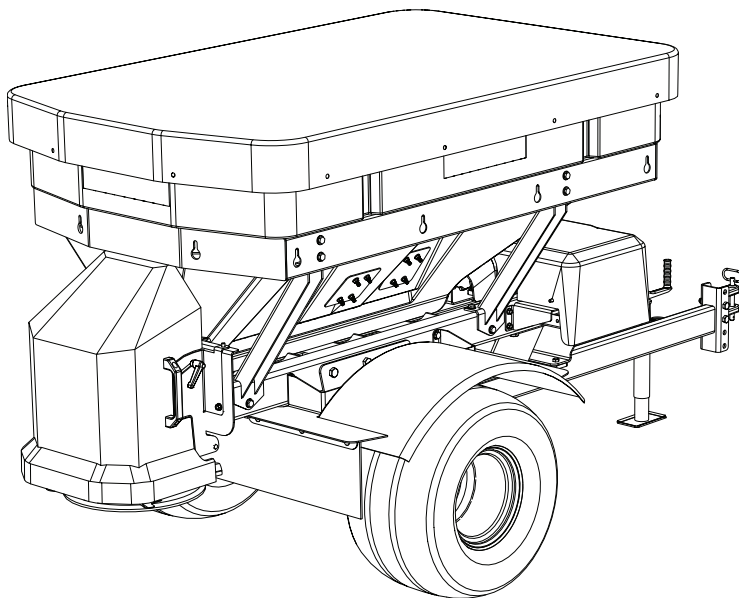

INNOVATIVE TURF SOLUTIONS



MS4500

Serial No. 140410300001MS4500 and higher



CUSTOMER COPY

Madison Heights, Michigan 48071
866-5-TURFEX
www.turfexproducts.com

Table of Contents



Introduction	3
Safety	4
Operating Instructions.....	4-7
Towing.....	5
Loading	5
Operating Control.....	6
Adjustable Spinner.....	8
Calibration Instructions	8
Maintenance Instructions.....	9
Maintenance.....	9
Preventing Corrosion.....	9
Storage.....	9
Troubleshooting	10-11
Spreader.....	10
Control.....	11
Notes.....	12-15

Have a question or need assistance?

TurfEx Customer Care

866-5-TURFEX

Monday through Friday 8:00 AM to 4:30 PM EST

E-mail: customercare@trynexfactory.com

Website: www.turfexproducts.com

This manual is intended to help you to get to know your TurfEx MS4500 spreader and how to operate it safely, correctly and economically. If you observe these instructions, you will prevent hazards, reduce repair costs and breakdown times, and increase the reliability and service life of the machine.

The manual must be read and used by every person who will be working with or on the machine for:

- Operation (including preparation, repair during operation, & clean-up)
- Repairs (maintenance, inspection, overhaul), and/or
- Transport.

All regulations for safety and proper working practice must be observed in addition to this manual and any applicable regulations for the prevention of accidents. Should you lose your Owner’s Manual or would like extra copies, they can be obtained from your TurfEx dealer or retrieved from the TurfEx website – www.turfexproducts.com.

SAFETY ALERT DEFINITION



This Safety Alert Symbol is used to pinpoint characteristics that, if not carefully followed, can create a safety hazard. When you see this symbol in this manual or on the machine itself, BE ALERT – your safety and the safety of others is involved.



DANGER

An accident will occur, resulting in Serious Injury or Death if the instructions are not followed.



WARNING

An accident may occur, resulting in Serious Injury, perhaps Death, if the instructions are not followed.



CAUTION

An accident may occur, resulting in Minor or Moderate Injury if the instructions are not followed.



Important Information; Property or Equipment Damage may result if not followed.

IMPORTANT EQUIPMENT INFORMATION

Record important machine information here for quick reference. The MS4500 Serial Number is found on the Serial Number Plate, located on the frame at the rear of the machine. The Control Serial Number is found on the bottom of the Control Pendant, by the plug. The Control Module Serial Number is found on the surface of the circuit board.

Model _____

Spreader Serial # _____

Control Serial # _____

Control Module Serial # _____

Date Purchased _____

Dealer where purchased _____

Example



SERIAL NUMBER DEFINITION	
CODE	DEFINITION
YY	2-Digit Year
MM	2-Digit Month
DD	2-Digit Date
LL	2-Digit Location Code
####	4-Digit Sequential Number
PPPPP	Assembly PN

Before attempting any procedure in this book, the safety information in this manual must be read and understood by all personnel who have any part in the installation, preparation, transport, service, repair or use of this equipment.

For your protection, safety and information decals have been placed on the spreader to remind the operator of safety precautions and particular hazards.

DANGER

Never exceed the Gross Vehicle Weight Rating, Hitch Capacity, or Towing Capacity. Failure to do so will result in unpredictable and unsafe vehicle handling.

Never operate equipment when under the influence of alcohol, drugs, or medications. These substances alter your judgment and slow your reactions.

Always keep hands, feet, clothing, jewelry, and hair away from moving parts. These items will catch and be pulled in by moving parts, causing serious personal injury.

Always shut off vehicle before attempting to attach, detach, or service the spreader. Be sure vehicle and equipment are properly braked, chocked, and on level ground.

Use caution when driving and drive at a sensible speed, where braking distances are safe and safe handling characteristics are maintained.

The tires on this equipment are not highway rated. Do not exceed 15 MPH.

WARNING

Before working with the spreader, secure all loose clothing and hair. Clothing and hair could get caught in moving parts.

Always wear safety glasses with side protection when servicing spreader or near where equipment is in use.

Never allow children to operate or climb/play on or around equipment.

Always make sure people are clear of where you will be using equipment. Always check areas to be spread to ensure no hazardous conditions or substances are in the area.

Inspect the spreader before and after operating for defects. Parts that are broken, missing or worn out must be replaced before operating.

Do not modify the spreader without written permission from TurfEx. Modifying the spreader or its mount can affect performance and safety.

CAUTION

Remember most accidents are preventable and caused by human error. Exercise care and observe precautions to prevent injury to yourself and others.

Never use wet materials or materials with foreign debris with the spreader. The spreader is designed to spread dry, clean, free-flowing material.

Never leave material in hopper between uses, or when storing. Materials can be hygroscopic and have a tendency to attract moisture and harden up.

Empty the spreader and clean it after each use to prevent spreading materials from building up and covering metal parts, possibly leading to corrosion.

Towing/Loading

TOWING

Back up the tow vehicle to the MS4500 so the vehicle's drawbar and the clevis hitch are aligned. Pin the clevis to the drawbar.

Connect the Spreader and Vehicle plugs.

Adjust the jack; pivot out of the way and lock.

LOADING SPREADER

Do not overload vehicle. Use the chart below to calculate the weight of spreader and material to comply with Vehicle Weight Ratings and Towing Capacities.

This spreader is designed to spread free-flowing sand that is relatively dry.

Empty weight of spreader:

985 lbs.

Approximate capacity:

37.8 cu.ft./1.4 cu.yd.

Use this chart when estimating the net weight of the spreader.

MATERIAL DENSITY CHART	
MATERIAL	DENSITY
Sand	80-100 lbs./cu. ft.
	2160-2700 lbs./cu. yd.
This chart is only intended for estimating Gross Vehicle Weight. It is not intended for calibration. To calibrate, you must measure and weigh your specific material.	

Leave the screen in the hopper when loading to prevent large chunks, debris, and foreign objects from entering the hopper and damaging the spreader.

Operating Control



Use the ON and OFF buttons to control the main power to the spreader.

Use START/STOP to turn the spinner and auger on and off. Use this as a pause button between passes or jobs.

Adjust SPINNER and AUGER speeds with the two sets of arrows. Speed will be displayed on the screens. Adjust to get your desired spread width and application rate – ‘Spread Pattern.’

Use the Vibrator to loosen ‘bridged’ material and improve flow to the auger with the VIBRATE button. The vibrator does not have to be on continuously.

BLAST turns both spinner and auger to max for as long as the button is held.

Turn the spreader OFF when you are done spreading and the machine is parked. The settings will remain for next time the spreader is used.

Operating Instructions

Adjustable Spinner

Your spreader is equipped with an adjustable spinner to assist in precise material application. The spinner plate gives the operator control of whether the material spreads toward the right, left, or is centered. Before operating the spreader, spread some material in a clear area where you can easily observe the spread pattern and how it changes with fin adjustment. Use the instructions below as a guide to get the spread pattern you desire. The position of the fins may need changed when using different materials or spreader settings.

When the fins are in their center adjustment position, the spread pattern will be centered (with most materials).

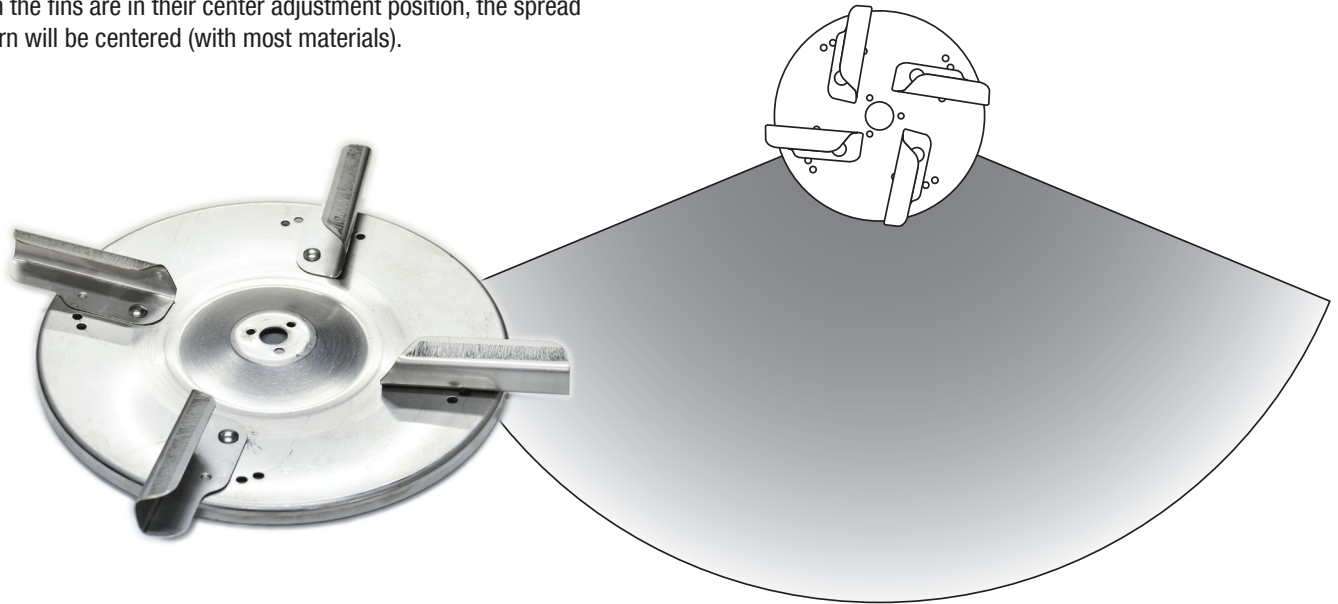

When looking down at the spinner, moving the fins clockwise will adjust the spread pattern toward the left side of the spreader.

When looking down at the spinner, moving the fins counter-clockwise will adjust the spread pattern toward the right side of the spreader.

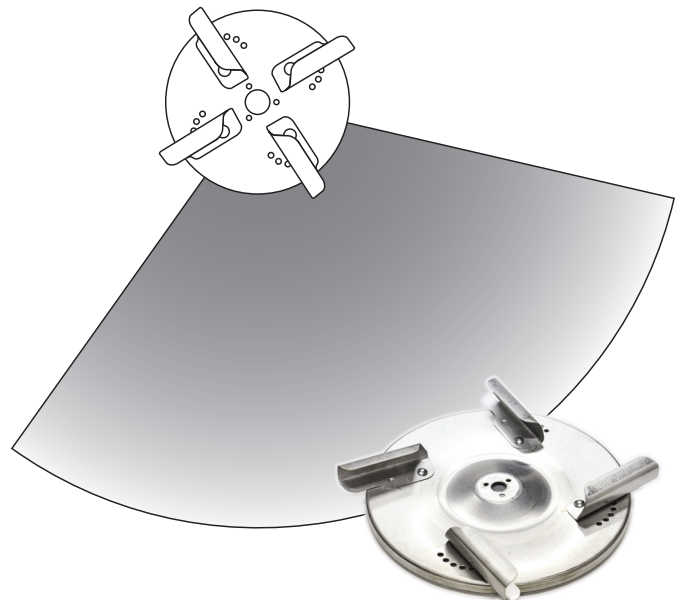
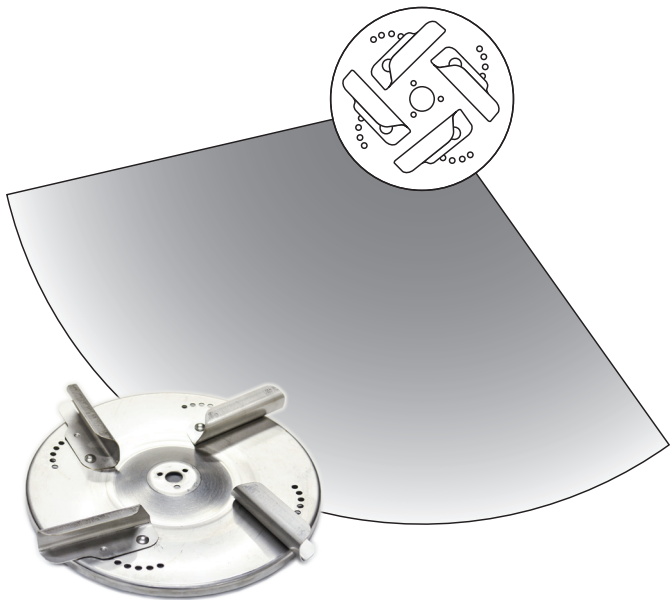

Calibration Instructions



All materials, regardless of physical similarities, flow and spread differently; Therefore, your spreader should be calibrated specifically for each material you are spreading.

Record calibration data for materials you commonly use. When calibrating, you may need to adjust your spinner fins to obtain an even spread pattern (see page 7 for spinner instructions).

MATERIALS NEEDED

To calibrate your spreader, you will need:

- Notepad
- Stopwatch
- Tape Measure
- Minimum 100' x 50' area for adjusting spread pattern and measuring width
- Tub/Tote (preferably 1 cubic foot when filled to the brim)
- Calculator

EQUATIONS, CALCULATION, AND SETUP

$$\text{Required Output} = (\text{Depth of Sand Required} \div 12) \times \text{Spread Width} \times \text{Speed}$$

cu. ft. per min. inches feet ft. per min.

$$\text{Time to Fill 1 cu. ft.} = 60 \div \text{Required Output}$$

seconds cu. ft. per min.

As shown by the first equation, to determine required output you need to determine three variables: Desired Depth of Sand, Spread Width, and Speed. Input the Desired Depth of Sand as inches; Spread width as feet; and Speed as feet per minute.

Spread Width can be anywhere from the range 10 to 30 feet. This should be a width that is appropriate for the area and you are comfortable spreading.

Speed should be one that can be consistently maintained across the whole area.

This leaves you with two things to find: the Auger Speed and Spinner Speed that will achieve the required output and spread width.

To find the Auger Speed you need to convert Required Output to the number of seconds it takes to fill one cubic foot, then find the corresponding Auger Speed. The Spinner needs removed so you can catch the discharge from the Chute in your plastic tub: unbolt the Spinner Hub from the Transmission by removing the bolt that goes through both of them. Turn on the spreader, adjust the Auger Speed to the approximate speed from the chart, check the time by doing a physical test and adjusting your Auger Speed based on the results. (When timing: start your stopwatch once the material begins coming down the Chute; stop when one cubic foot is filled.)

Adjust the Spinner Speed to match the width you have selected.

You may need to adjust the spinner fins to even out the spread pattern depending on material.

Record all this information for future reference: Auger Speed, Spinner Speed, Spinner Fin Position, Spread Width, Speed, Material, Depth, and Application.

AUGER SPEED AND CORRESPONDING OUTPUT		
Auger Speed	Cubic Feet Per Minute	Seconds Per Cubic Foot
10	2.50	24.00
20	3.00	20.00
30	3.25	18.46
40	3.50	17.14
50	3.75	16.00
60	4.00	15.00
70	4.25	14.12
80	4.50	13.33
90	4.75	12.63
99	5.00	12.00

Maintenance



- Perform service indoors or in a sheltered area.
- Avoid Electric Shock. Do not use power tools in rain or snow.
- Disconnect electricity to spreader before servicing.
- Do not attempt to service controls, motors, or transmissions.
- Use Genuine TrynEx Parts.

MAINTENANCE

- Recharge batteries after each use.
- Use dielectric grease on all electrical connections. Apply at the beginning and end of each season; and after washing the spreader.
- Wash equipment after each use. Do not use pressure washers near bearings, transmissions, and motors.
- Paint or oil all bare metal at the end of the season to prevent exposure to moisture.
- Lubricate bearings and pivots every twenty hours of use.
- Tighten hardware after first use.
- Empty the spreader after each use. Moisture can build up in the material and overload the auger when the spreader is used again.

PREVENTING CORROSION

Corrosion/Rust is a chemical reaction caused by presence of moisture, air, and metal. Preventing any one of these ingredients from coming in contact with any other ingredient will prevent corrosion.

Here are some recommended measures to take:

- Store equipment indoors
- Clean/Rinse thoroughly after each use
- Lubricate moving parts
- Touch-Up/Oil chipped paint
- Use a spray-on car wash wax
- Use rust inhibitor

STORAGE

How you store your spreader can have a lot to do with how long it lasts and how well it performs. Store your spreader in a sheltered area, preferably indoors. If it must be stored outside, cover with a tarp. Put Dielectric Grease on all plugs and connections prior to storage.

Before storing your spreader for an extended period of time: perform a very thorough cleaning, lubricate bearings, and oil or paint metal parts (does not apply to stainless steel); Apply a protective plastic conditioner to the hopper and vinyl conditioner to the hopper cover; Instead of oil on the frame, you can use a rust inhibitor spray (read the label before using to make sure it is not damaging to paint).

Spreader

PROBLEM	POSSIBLE CAUSE	SOLUTION
Motor doesn't run	Loose electrical connections	Check all connections
	Motor seized	Replace motor
Material not flowing from hopper	Hopper is empty	Fill hopper
	Material is wet	Replace with clean, dry, free-flowing material
	Coarse material	Replace with clean, dry, free-flowing material
	Auger loose on shaft	Align/Tighten Coupler
		Tighten bearing
	Vibrator not working	Check connections
Material free flows		Replace vibrator
	Chute in up position	Check/repair mechanical connection
		Check/repair electrical connection
		Bad actuator. Replace
Material free flows	Chute in down position	Check/repair mechanical connection
		Check/repair electrical connection
		Bad actuator. Replace
Poor spread pattern	Spinner fins	Adjust spinner fins

Control

PROBLEM	POSSIBLE CAUSE	SOLUTION
Control shut down	Jammed auger	Clear jammed auger. Use caution
	Poor electrical connections	Clean/replace connectors
		Use dielectric grease
	Electrical short	Check all connections
		Check for bare wires
	Control failure	Replace Control Module
OL/OH	Jammed auger	Switch off, then on (for Auto-Reverse)
		If it continues. Turn off. Clear jam
	Bad Connection	Check connections/Dielectric grease
		Clean/replace connectors
	Bad motor	Check with Test Kit
	Bad transmission	Replace
	Bad Control Module	Check with Test Kit
EO	Motor is not getting power	Turn Off. Check all connections
	Break in wiring harness	Repair/Replace
E1	Short in motor circuit	Turn off. Do not use until short is corrected
		Check/Replace connections
		Check for bad motor
LB	Low Battery	Turn off. Charge battery
	Poor connection	Turn Off. Check all connections
No Display. Nothing lights up	Bad Control or Bad Control Module	Check with Test Kit
	Bad Pendant Cord	Replace

Parts List

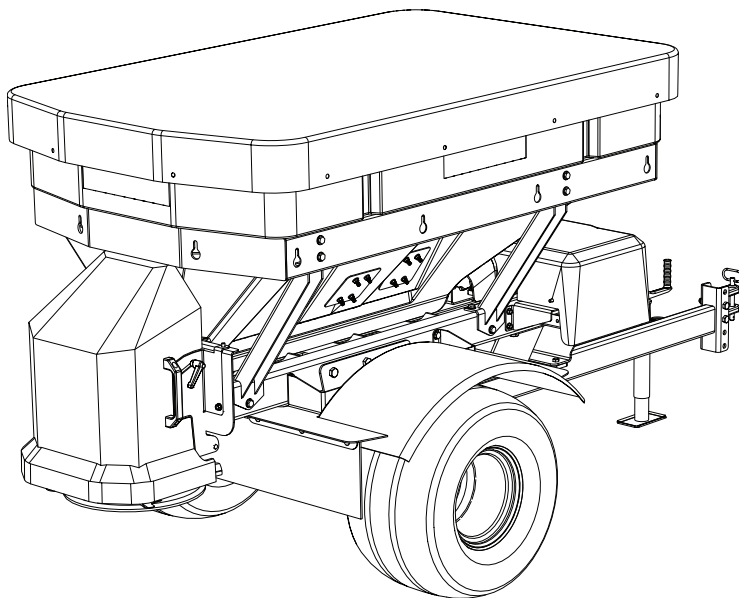

MS4500

Serial No. 140410300001MS4500 and higher



Madison Heights, Michigan 48071
866-5-TURFEX
www.turfexproducts.com

CUSTOMER COPY

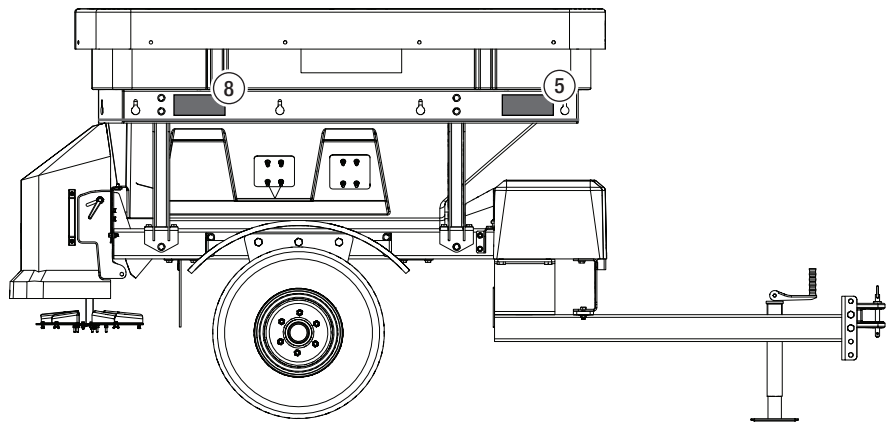
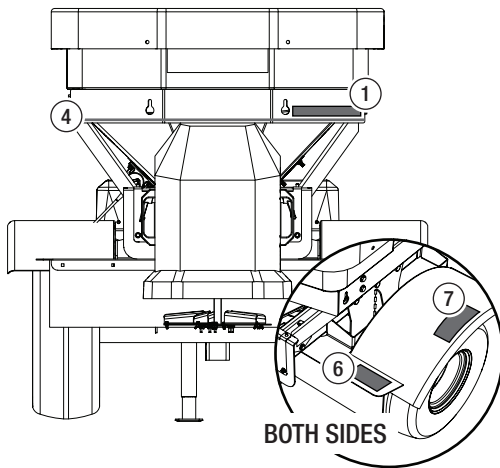

② D6192

⚠ WARNING
<ul style="list-style-type: none"> • Keep hands, feet & loose clothing away from moving parts. • Disconnect power before servicing equipment.
D6192

③ D6194

⚠ WARNING
<ul style="list-style-type: none"> • Read owners manual before operating equipment. • Never remove spreader with material in hopper.
D6194

④ D6229

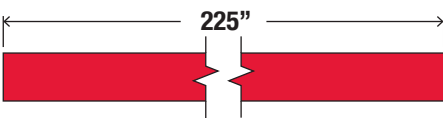

⑤ D6335

	⚠ WARNING
	<p>ROTATING AUGER CAN CAUSE SERIOUS INJURY OR DEATH</p> <ul style="list-style-type: none"> • Keep arms, hands, and loose clothing away from auger. • Shut off control and unplug spreader before servicing.
	D6335

⑥ D6544

	⚠ WARNING
	<p>ROTATING PARTS AND FLYING OBJECTS CAN CAUSE INJURY OR DEATH</p> <ul style="list-style-type: none"> • Keep hands, arms, feet and loose clothing away • Shut off power and stop engine before servicing • Read owners manual before operating. • Keep bystanders at least 60 ft away.
	D6544

⑦ D6545

	⚠ WARNING
	<p>NO STEP</p> <ul style="list-style-type: none"> • Slippery Surface When Wet. • May Cause Severe Injury
	D6545

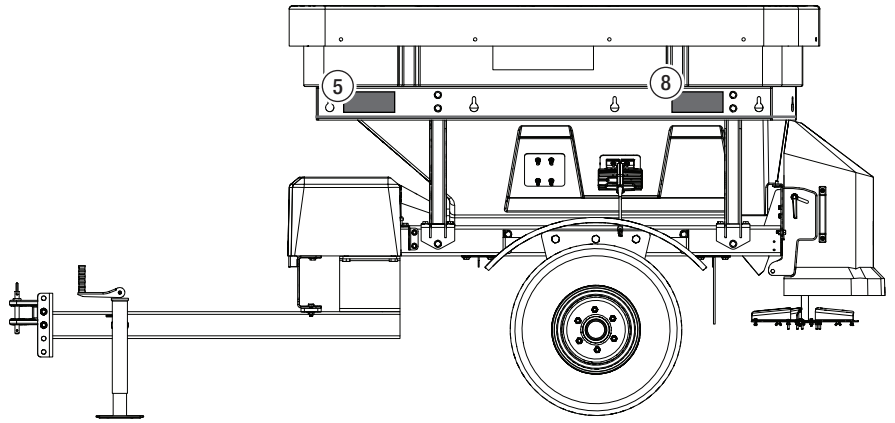
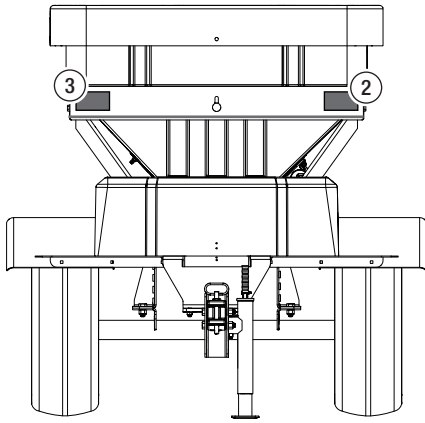

① T30757
MS4500

⑧ T30800



ID #	PART #	QTY	DESCRIPTION
1	D6192	1	Decal Warning - Hands & Feet/Disconnect Power
2	D6194	1	Decal Read Owner's Manual
3	D6229	225	Red Stripe 225 inches
4	D6335	2	Decal Warning - Rotating Auger
5	D6544	2	Rotating Parts
6	D6545	2	Decal Warning - No Step
7	T30757	1	Decal Die Cut - MS4500
8	T30800	2	Decal Warning - Sloped Terrain

Wiring Schematic

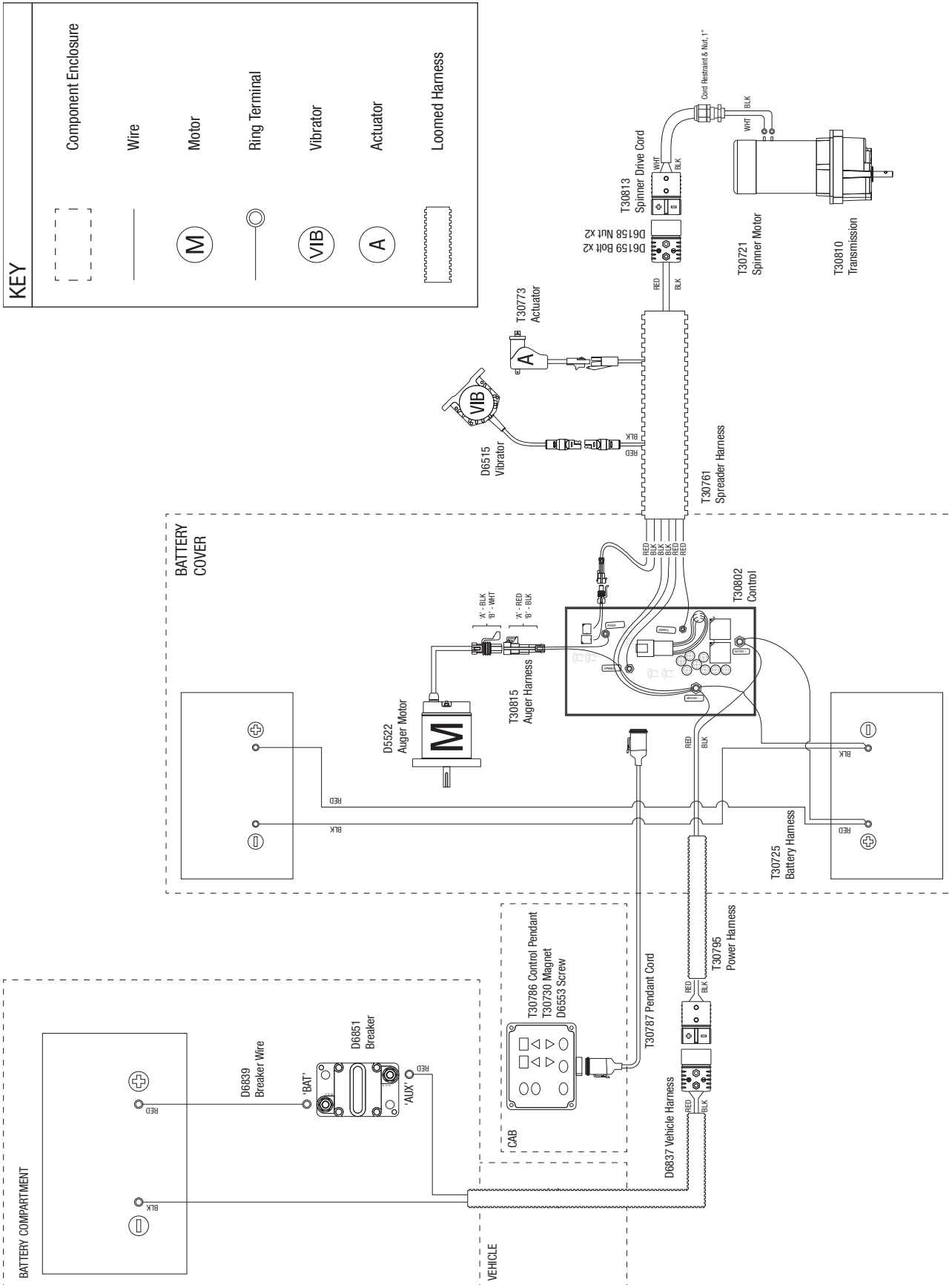

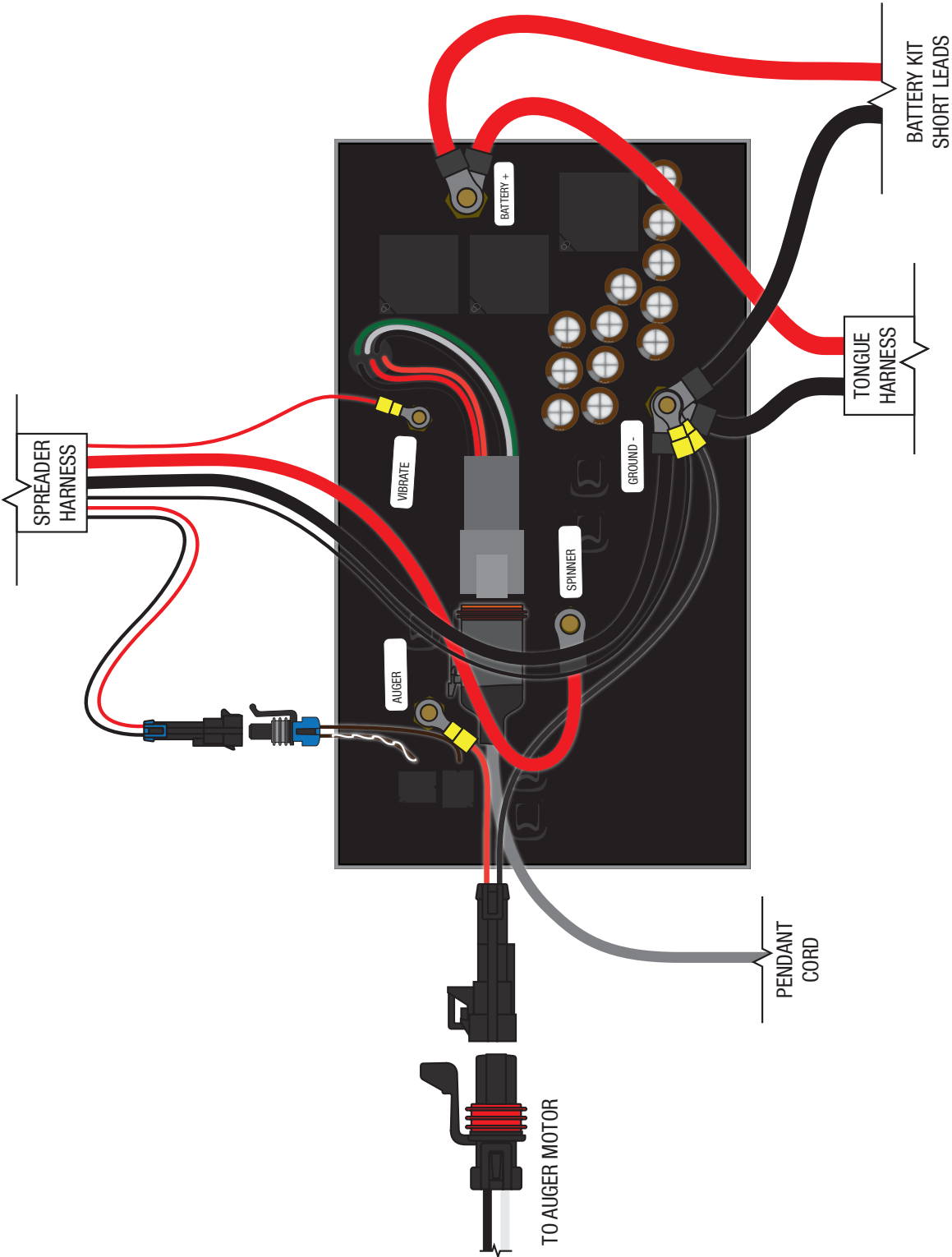

Frame Assembly Parts Breakdown

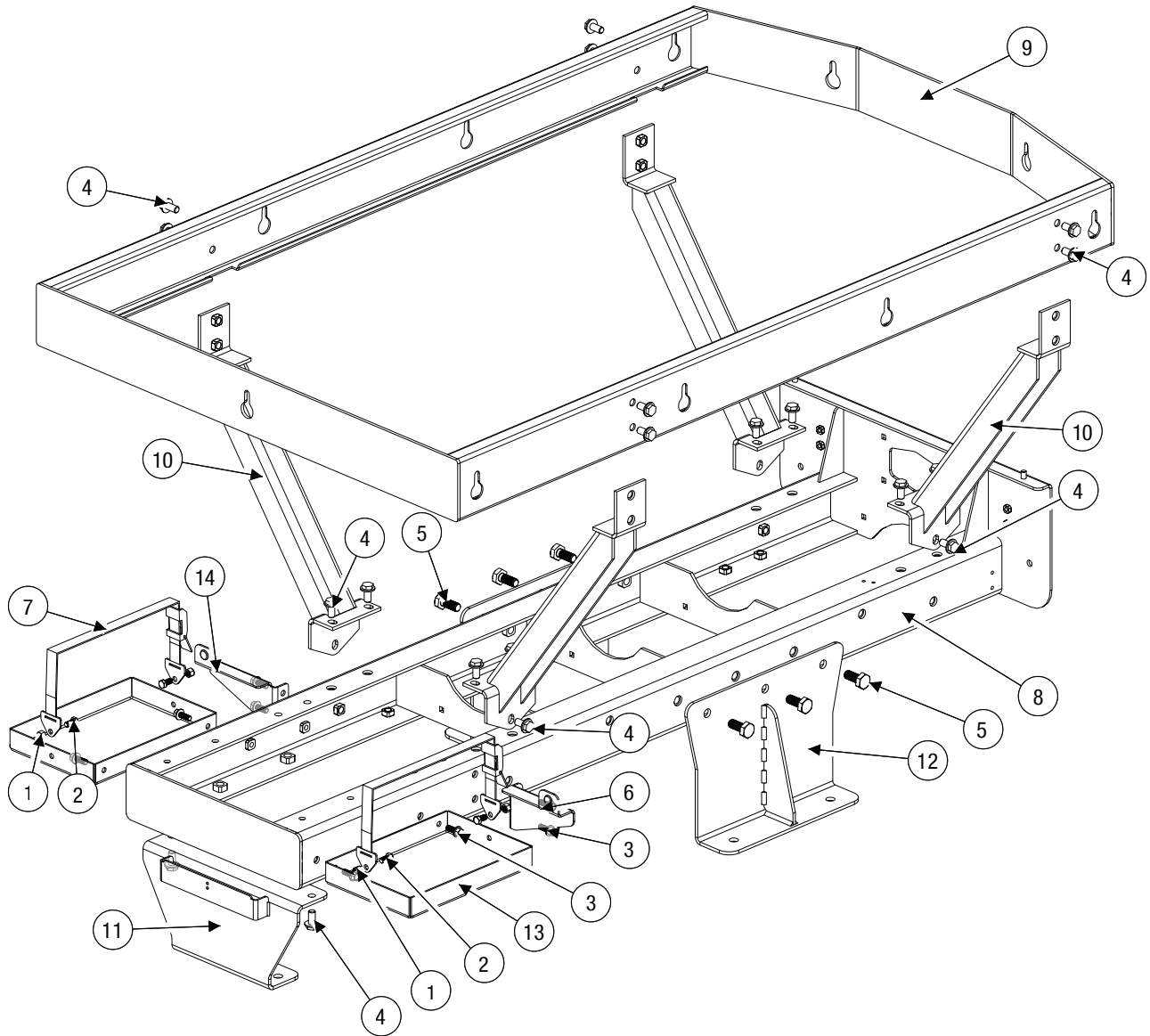

Frame Assembly Parts Breakdown



ID #	PART #	QTY	DESCRIPTION
1	D4124	4	NUT 3/8"-16 NYLOX ZINC
2	D5340	4	BOLT 3/8"-16 X 3/4" HEX HEAD, ZINC
3	D6452	8	BOLT, 3/8-16 X 1, SERR FLANGE TYPE F, ZINC
4	D6528	22	BOLT 1/2"-13 X 1", SERRATED HEX ZINC
5	T30740	6	BOLT 5/8"-11 X 1-1/2", HEX HEAD ZINC
6	T30747	1	BATTERY COVER MOUNT BRACKET, LEFT
7	T30749	2	BATTERY STRAP
8	T30754	1	MAIN FRAME TOWABLE
9	T30774	1	FRAME BELT
10	T30775	4	FRAME UPRIGHTS
11	T30776	1	HITCH MOUNT
12	T30782	2	AXLE MOUNT PLATE
13	T30788	2	BATTERY TRAY
14	T30797	1	BATTERY COVER MOUNT BRACKET, RIGHT

Hopper Assembly Parts Breakdown

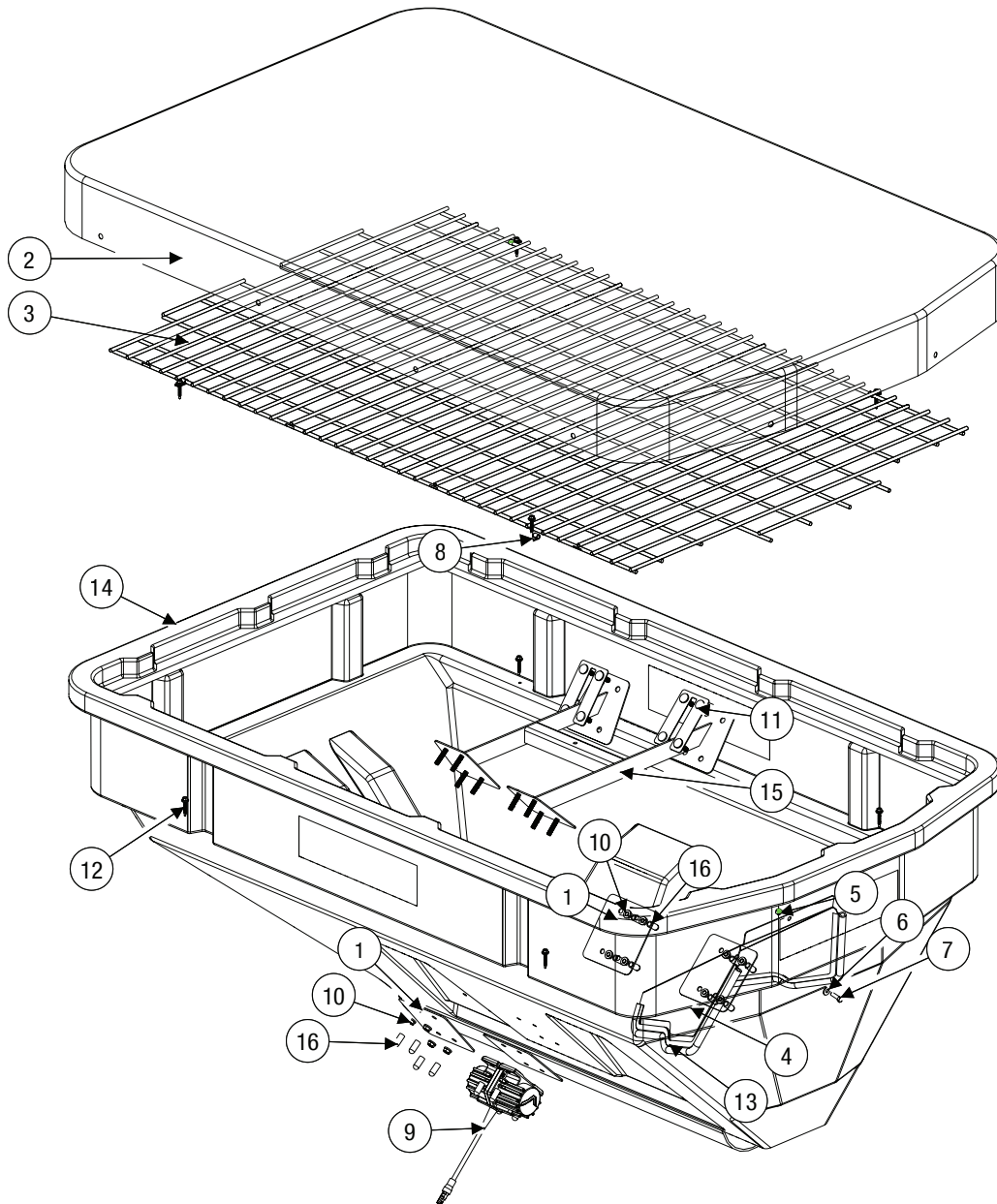

Hopper Assembly Parts Breakdown



ID #	PART #	QTY	DESCRIPTION
1	D5508	4	FLAT INVERTED V BACKING PLATE
2	D5511	1	TARP KIT 78" X 49"
3	D5512	1	TOP SCREEN 72" X 43"
4	D5517	1	DISCHARGE BAFFLE
5	D6138	1	NUT, 5/16-18, NYLOX, ZINC
6	D6165	1	WASHER, 5/16, FLAT USS, ZINC
7	D6166	1	BOLT 5/16"-18 X 1", HEX HEAD ZINC
8	D6509	4	CLAMP, 5/16, RUBBER COATED
9	D6515	1	VIBRATOR, DC 200
10	D6584	16	NUT, 5/16-18, SERRATED FLANGE ZINC
11	D6815	2	BOLT PLATE 4 BOLT
12	D6874	8	SCREW, 1/4" X 1-1/2", DRILLER W/R-M WASHER
13	T30008	45	EDGE GRIP SEAL
14	T30750	1	HOPPER 1.4 CU. YD. MOCHA
15	T30758	1	VIBRATION FRAME
16	T30820	16	STUD COVER 3/8" X 1" PLASTIC

Auger Drive Parts Breakdown

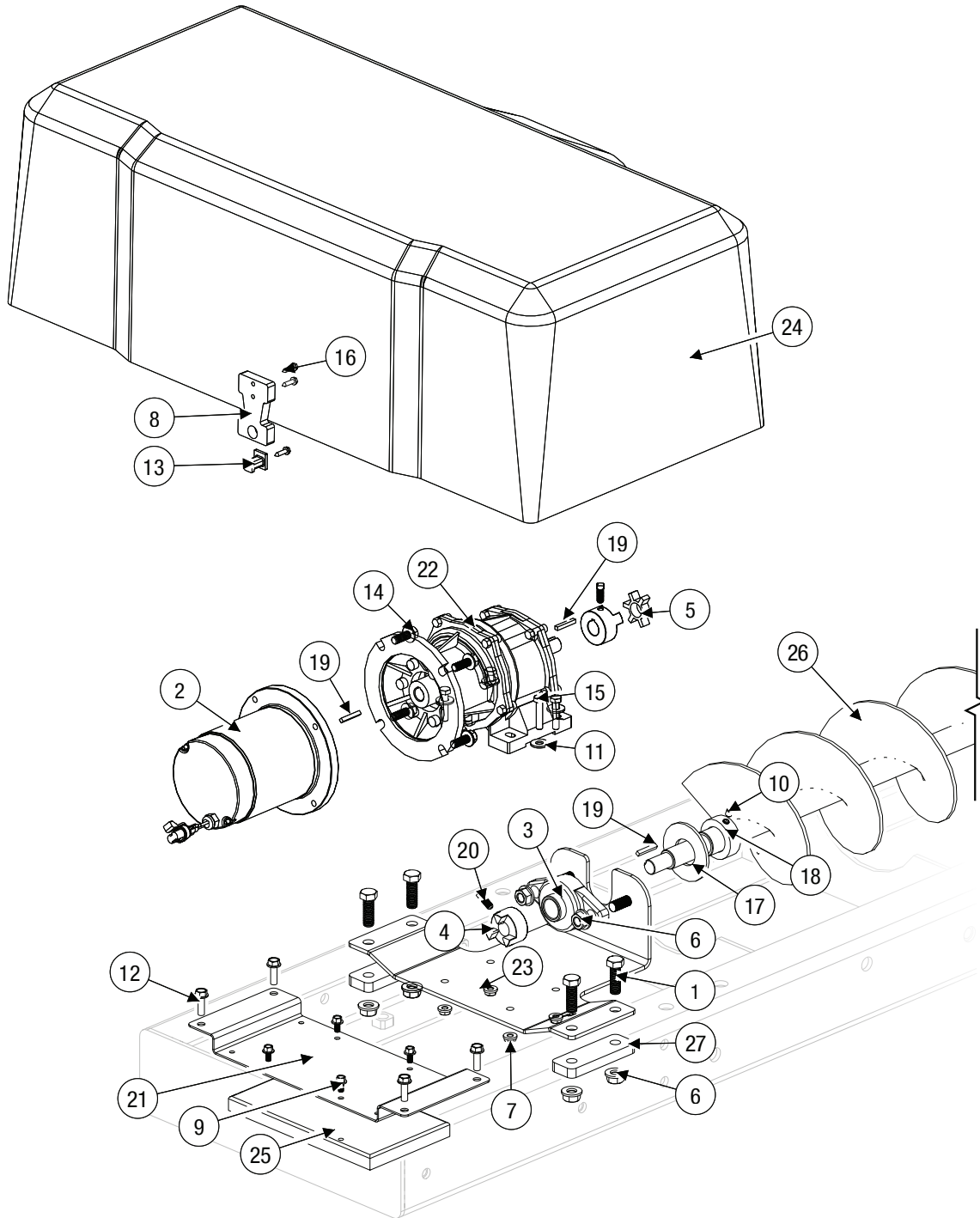

Auger Drive Parts Breakdown



ID #	PART #	QTY	DESCRIPTION
1	D4116	4	BOLT 1/2"-13 X 1-1/2", HEX HEAD ZINC
2	D5522	1	MOTOR 1/3HP X 1750RPM
3	D5527	1	BEARING 1" 2 BOLT FLANGE
4	D5532	2	JAW-COUPLING HUB, L075 SINTERED IRON
5	D5533	1	JAW-COUPLING SPIDER, L075 URETHANE
6	D5535	6	NUT 1/2"-13 SERRATED FLANGE, ZINC
7	D5706	4	NUT 5/16"-18 SERRATED FLANGE, ZINC
8	D6105	1	FLEXIBLE DRAW LATCH
9	D6131	4	BOLT, 1/4-20 X 1/2, SERR FLANGE, STAINLESS
10	D6140	1	SET SCREW, 5/16-18 X 3/8, SOCKET HEAD
11	D6165	4	WASHER, 5/16, FLAT USS, ZINC
12	D6182	4	BOLT 5/16"-18 X 1" TYPE F, FLANGE ZINC
13	D6198	1	LATCH KEEPER
14	D6452	4	BOLT, 3/8-16 X 1, SERR FLANGE TYPE F, ZINC
15	D6524	4	BOLT, 5/16-18 X 1-1/2, TAP, ZINC
16	D6553	3	SCREW #10 X 3/4" HWH SLOTTED, SMS ZINC
17	D6789	1	WASHER 1-1/4" FLAT USS ZINC
18	D6792	1	SHAFT COLLAR 1-5/16", W/SET SCREW ZINC
19	D6873	3	KEYSTOCK 3/16" X 1-1/4", PLAIN
20	D7162	2	SET SCREW 5/16"-18 X 3/4", SQ HEAD PLAIN
21	T30745	1	CONTROL MOUNTING BRACKET
22	T30767	1	MS4500 AUGER TRANS
23	T30791	1	AUGER DRIVE MOUNT BRACKET
24	T30793	1	BATTERY COVER BLACK
25	T30802	1	SPREADER CONTROL MS4500
26	T30808	1	AUGER 7" X 53-1/4" 5"-8"
27	T30811	2	AUGER DRIVE SPACER PLATE

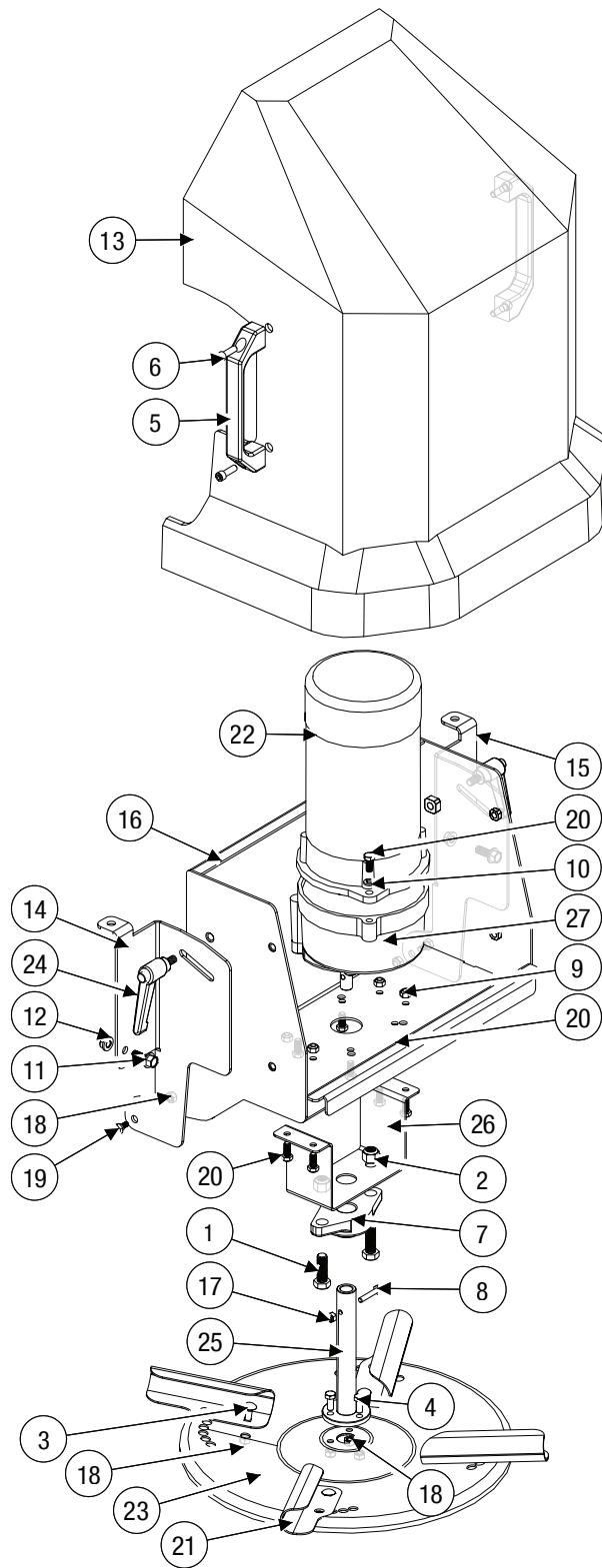

Spinner Drive Parts Breakdown



ID #	PART #	QTY	DESCRIPTION
1	D4116	2	BOLT 1/2"-13 X 1-1/2", HEX HEAD ZINC
2	D4120	2	NUT 1/2"-13 NYLOX ZINC
3	D5022	4	BOLT 5/16-18 X 3/4 CARRIAGE, STAINLESS
4	D5209	3	BOLT 5/16"-18 X 3/4", HEX HEAD STAINLESS
5	D5248	2	PULL HANDLE 8"
6	D5293	4	BOLT 5/16"-18 X 1", SOCKET HEAD STAINLESS
7	D5527	1	BEARING 1" 2 BOLT FLANGE
8	D5907	1	BOLT 1/4"-20 X 1-3/8", HEX HEAD STAINLESS
9	D6138	4	NUT, 5/16-18, NYLOX, ZINC
10	D6155	2	LOCK WASHER 5/16" ZINC
11	D6452	2	BOLT, 3/8-16 X 1, SERR FLANGE TYPE F, ZINC
12	D6584	2	NUT, 5/16-18, SERRATED FLANGE ZINC
13	F51168	1	SPINNER COVER ASSEMBLY TOW PRO
14	F51171	1	SPINNER DRIVE MOUNT PLATE, RIGHT
15	F51172	1	SPINNER DRIVE MOUNT PLATE LEFT
16	F51173	1	SPINNER DRIVE ENCLOSURE MS4500
17	T15016	1	NUT 1/4"-20 NYLOX WAXED, STAINLESS
18	T15018	9	NUT 5/16"-18 NYLOX WAXED, STAINLESS
19	T15038	2	BOLT GATE LINKAGE SHOULDER, STAINLESS
20	T15111	10	BOLT 5/16"-18 X 3/4", HEX HEAD ZINC
21	T30207	4	CUPPED SPINNER FIN
22	T30721	1	MS4500 SPINNER MOTOR
23	T30723	1	SPINNER PLATE 17" DISHED
24	T30796	2	ADJUSTABLE HANDLE, 3/8"-16 X 1"
25	T30804	1	SPINNER HUB, 5/8" X 1" X 7-1/2"
26	T30809	1	SPINNER BEARING BRACKET
27	T30810	1	TRANSMISSION 4.81:1 IN-LINE

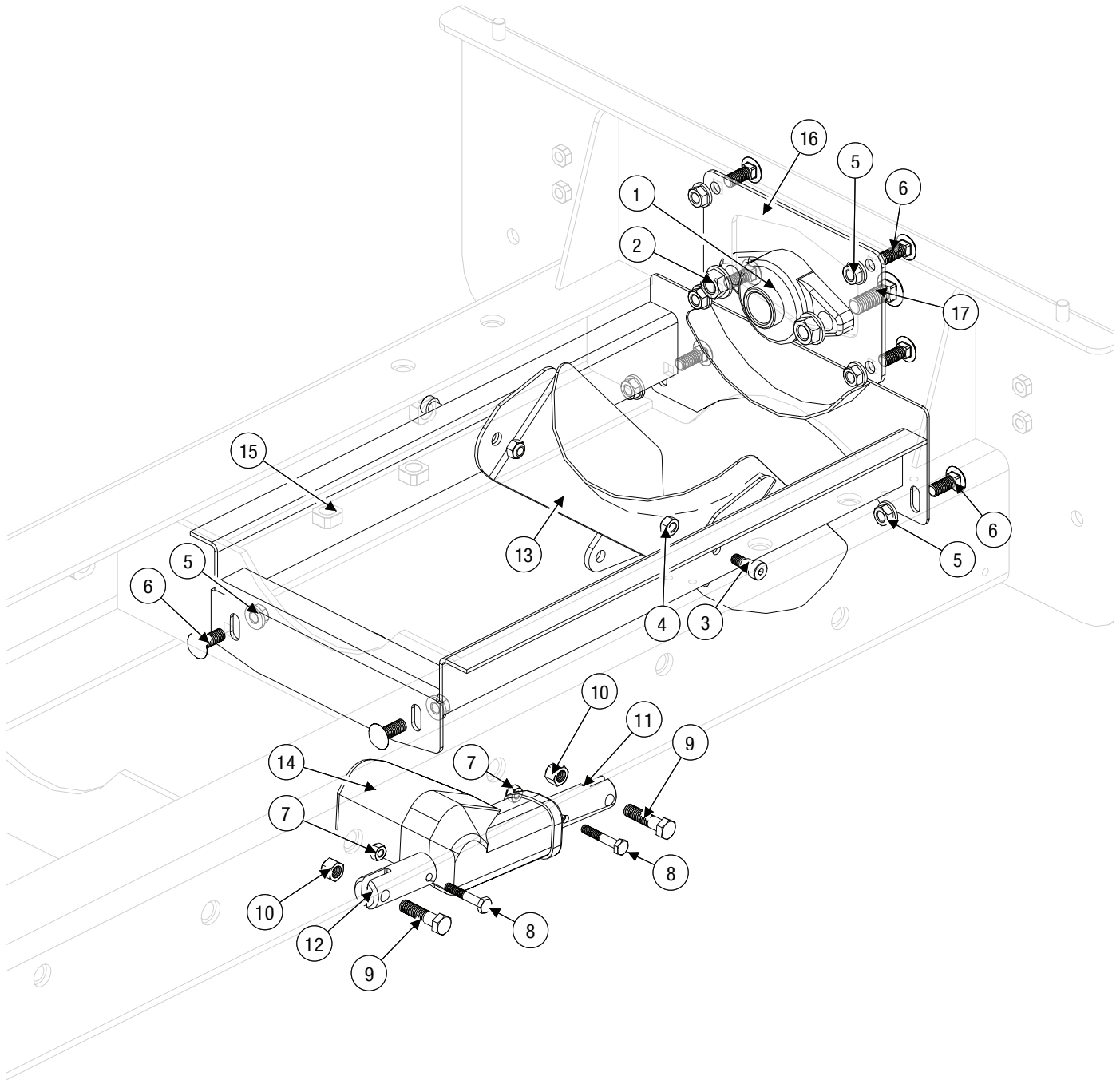

Chute Assembly / Rear Bearing Parts Breakdown



ID #	PART #	QTY	DESCRIPTION
1	D5527	1	Bearing 1" 2 Bolt Flange
2	D5535	2	Nut 1/2"-13 Serrated Flange Zinc
3	D5536	2	Bolt 3/8" X 5/16" Socket Shoulder
4	D6138	2	Nut 5/16"-18 Nylox Zinc
5	D6584	8	Nut 3/8"-16 Serrated Flange Zinc
6	D6810	8	Bolt 3/8"-16 X 1" Carriage Zinc
7	T15016	2	Nut 1/4"-20 Nylox Waxed Stainless
8	T30726	2	Bolt 1/4"-20 X 1-1/2" Hex Head Stainless
9	T30727	2	Bolt 3/8"-16 X 1-1/2" Hex Head Stainless
10	T30728	2	Nut 3/8"-16 Nylox Waxed Stainless
11	T30729	1	Actuator Rod Adapter
12	T30744	1	Actuator Mount Adapter
13	T30769	1	Chute Gate
14	T30773	1	Linear Actuator 2" Stroke
15	T30798	1	Gate Frame
16	T30814	1	Auger Bearing Adapter Bracket
17	T30821	2	Bolt 1/2"-13 X 1-1/2" Carriage Zinc

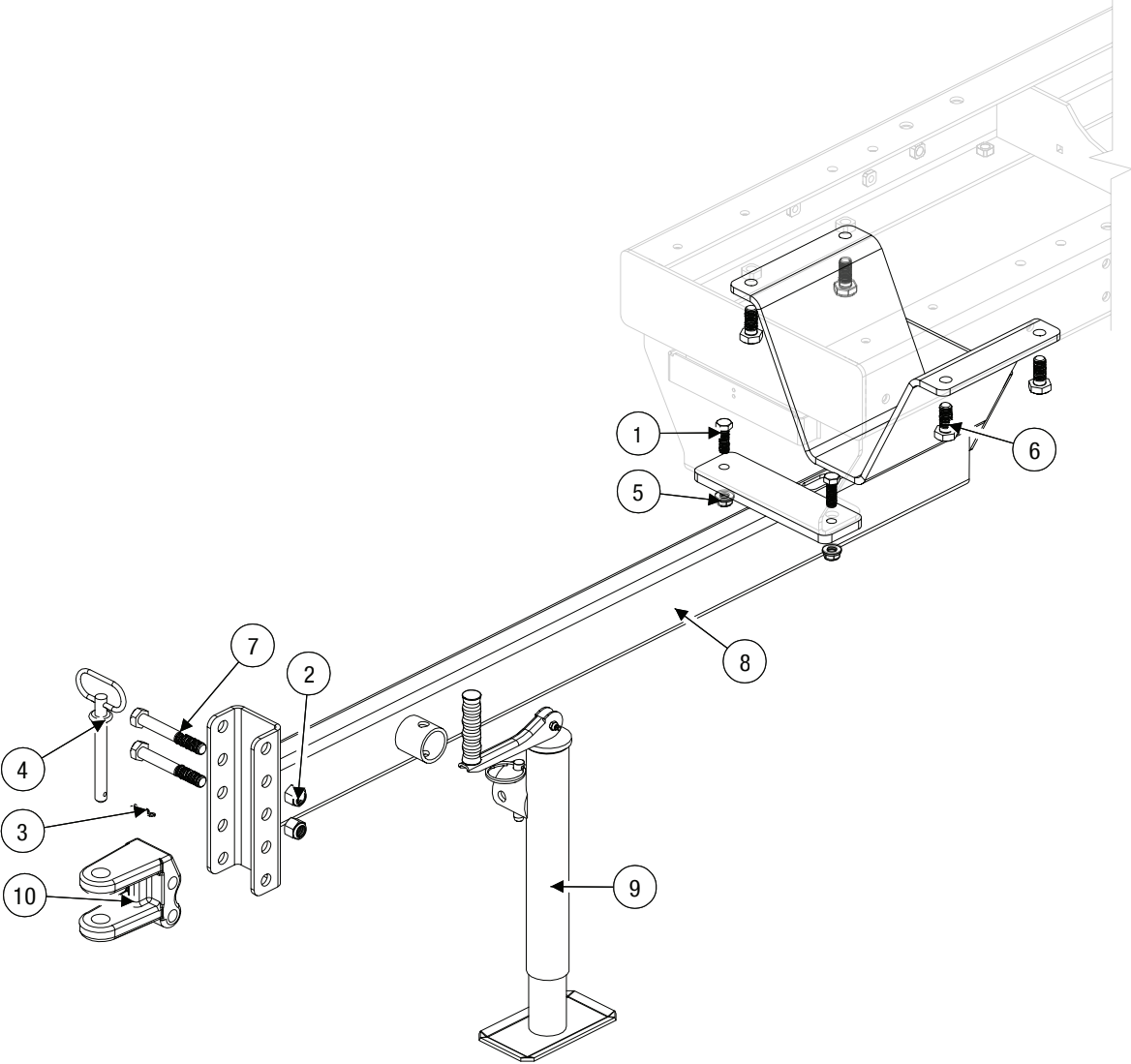

Trailer Tongue Parts Breakdown



ID #	PART #	QTY	DESCRIPTION
1	D4116	2	Bolt 1/2"-13 X 1-1/2" Hex Head Zinc
2	D4127	2	Nut 5/8"-11 Nylox Zinc
3	D4135	1	Hair Pin Cotter .093 X 2-3/8" Zinc
4	D4136	1	Hitch Pin 5/8" X 5-1/2"
5	D5535	2	Nut 1/2"-13 Serrated Flange Zinc
6	T30740	4	Bolt 5/8"-11 X 1-1/2" Hex Head Zinc
7	T30741	2	Bolt 5/8"-11 X 4-1/2" Hex Head Zinc
8	T30755	1	Trailer Tongue
9	T30789	1	Trailer Jack
10	T30790	1	Hitch Clevis

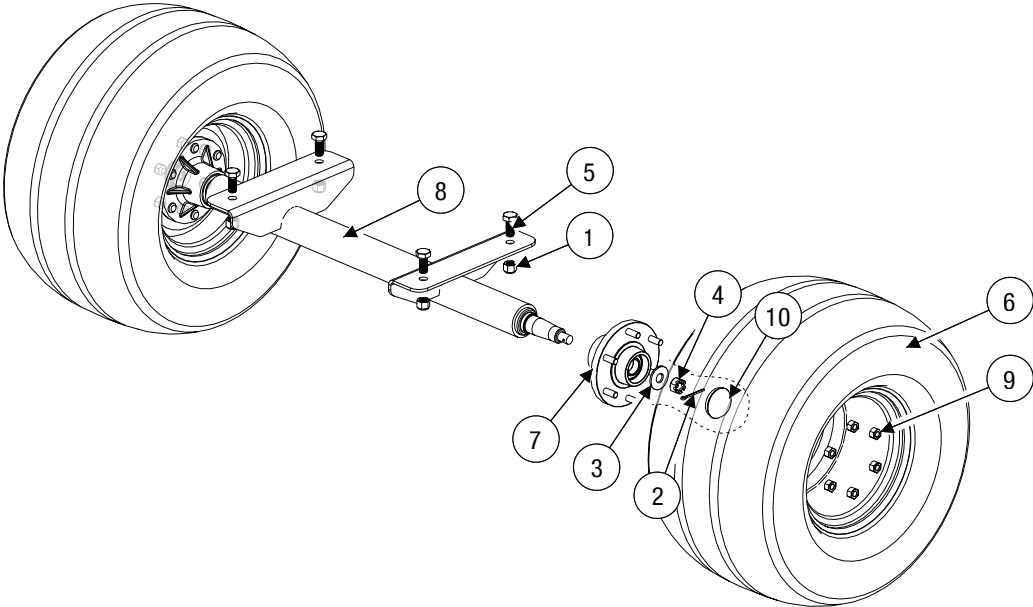

Wheel & Axle Parts Breakdown



ID #	PART #	QTY	DESCRIPTION
1	D4127	4	NUT 5/8"-11 NYLOX ZINC
2	T30736	2	COTTER PIN 5/32" X 2" ZINC
3	T30738	2	WASHER 3/4" FLAT USS ZINC
4	T30739	2	NUT 3/4"-16 SLOTTED HEX ZINC
5	T30740	4	BOLT 5/8"-11 X 1-1/2", HEX HEAD ZINC
6	T30751	2	TURF TIRE 26.5 X 14 X 12
6	T30752	2	RIM 12 X 10.5
7	T30753	2	WHEEL HUB 6 X 6
8	T30756	1	AXLE 2-7/8" X 46"
9	T30780	12	NUT 1/2"-20 WHEEL, 13/16" HEX ZINC
10	T30781	2	AXLE CAP

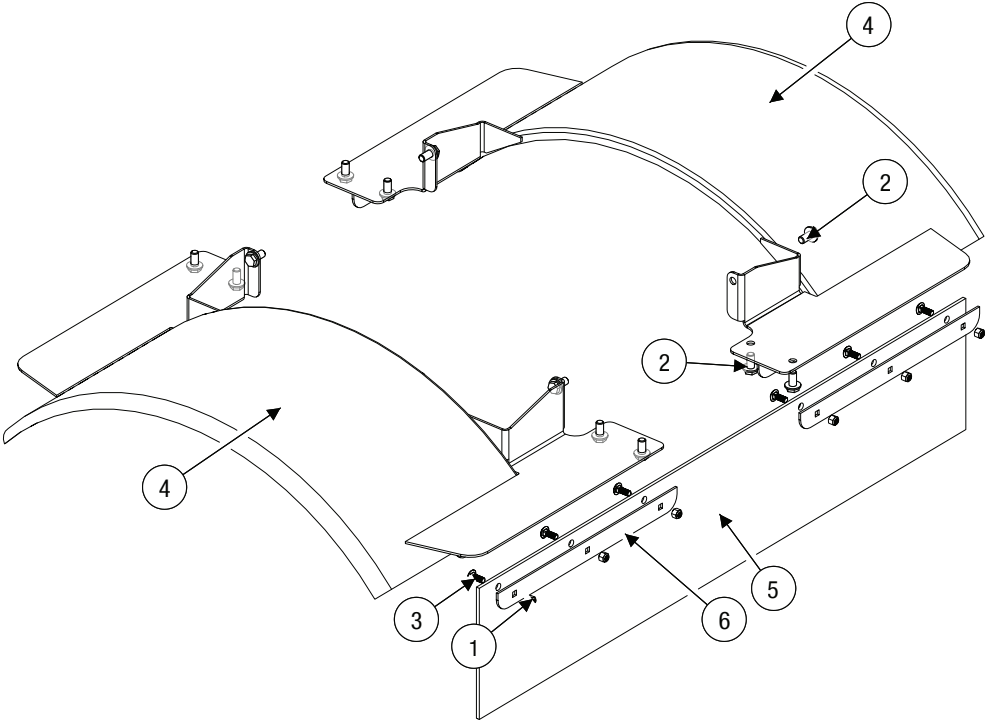

Fender Parts Breakdown



ID #	PART #	QTY	DESCRIPTION
1	D4124	6	Nut 3/8"-16 Nylox Zinc
2	D6528	12	Bolt 1/2"-13 X 1" Serrated Hex Zinc
3	D6810	6	Bolt 3/8"-16 X 1" Carriage Zinc
4	T30784	2	Fender 16"
5	T30816	1	Mud Flap 1/4" X 10" X 50"
6	T30817	2	Mud Flap Clamp Plate

Assembly Instructions

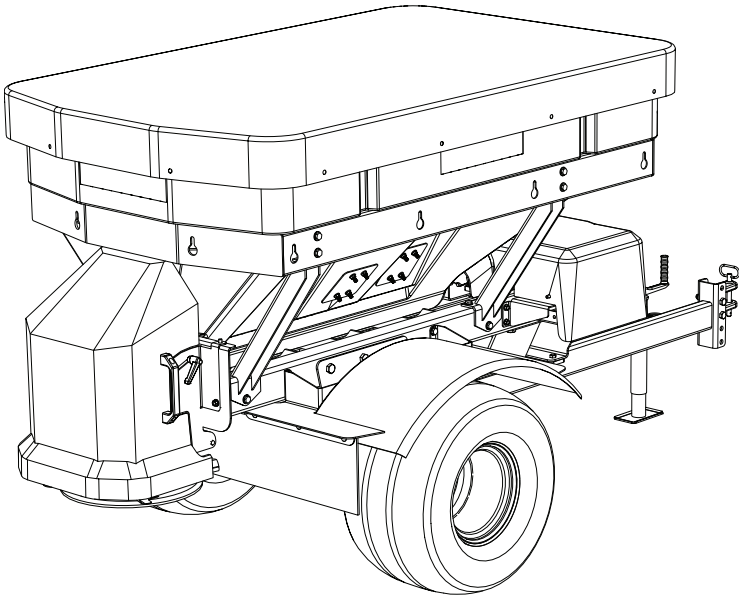

MS4500
Serial No. 140410300001MS4500 and higher



CUSTOMER COPY

Madison Heights, Michigan 48071
866-5-TURFEX
www.turfexproducts.com

These Installation Instructions have been designed to guide you while assembling and installing your TurfEx spreader. Follow these instructions with care to ensure performance and longevity.

Please read and understand the safety warnings associated with the assembly and installation of the spreader before beginning. In addition the safety information in the these instructions, observe general safety guidelines to maintain your safety and the safety of those around you.

SAFETY ALERT DEFINITION



This Safety Alert Symbol is used to pinpoint characteristics that, if not carefully followed, can create a safety hazard. When you see this symbol in this manual or on the machine itself, BE ALERT – your safety and the safety of others is involved.



DANGER

An accident will occur, resulting in Serious Injury or Death if the instructions are not followed.



WARNING

An accident may occur, resulting in Serious Injury, perhaps Death, if the instructions are not followed.



CAUTION

An accident may occur, resulting in Minor or Moderate Injury if the instructions are not followed.



Important Information; Property or Equipment Damage may result if not followed.

TORQUE CHART

Use this chart as a guide for tightening hardware.

Hand-tighten all fasteners until complete, then tighten to the recommended torque (unless specified otherwise in these instructions).

TORQUE CHART FT-LB	
Fastener	Recommended Torque (ft-lb)
1/4-20	6
5/16-18	13
3/8-16	23
7/16-14	35
1/2-13	55
9/16-12	80
5/8-11	110
3/4-10	200
7/8-9	320
1-8	480

Assembly Instructions



STEP 1

Unpack the spreader; remove the axle, tires, tongue, and spinner drive from the pallet, set aside so the main spreader assembly is alone on the pallet.

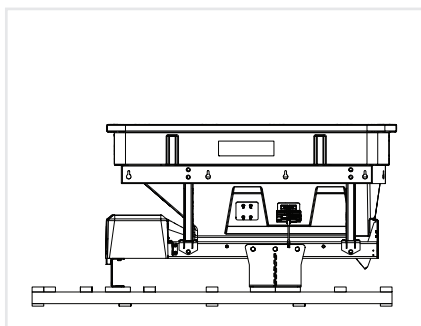

STEP 2

Open the Spinner Drive Box. Open and locate the hardware kits.

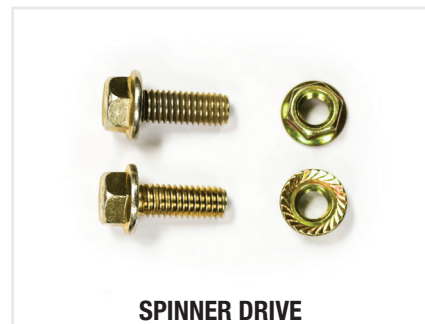

STEP 3

Remove the lag bolts holding the spreader to the pallet.

STEP 4

Lift the spreader and support it to allow installation of the axle and trailer tongue. Once lifted, remove and discard the pallet. As a safeguard, in addition to the support jacks underneath the spreader, leave the lifting device in place.

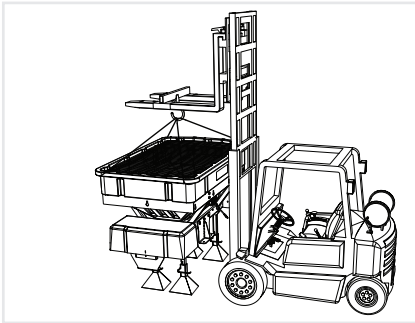

**IF USING FORKLIFT,
BRACE THE MAST.**

STEP 5

Fasten the Axle to the frame.

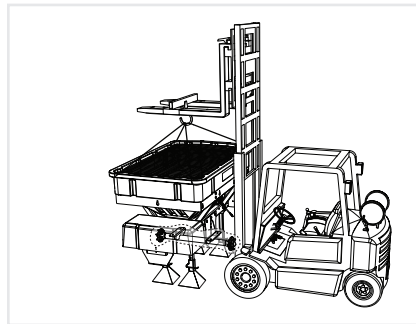
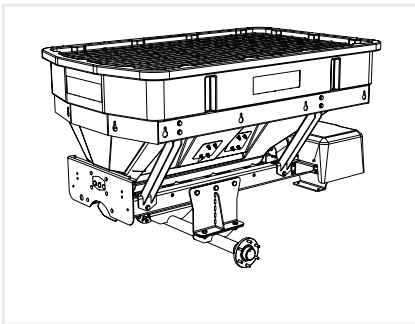

STEP 6

Mount the wheels, tighten the lug nuts.

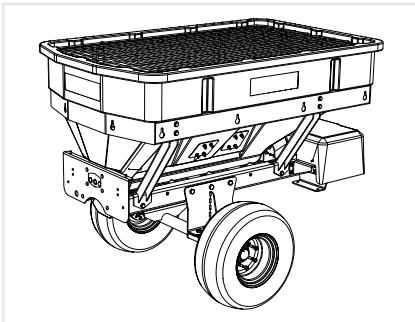

STEP 7

Attach the tongue. It bolts directly to the frame and to the hitch mount at the front of the trailer. Connect the leads of the trailer harness to the control board: Red to "BAT +" and Black to "GROUND". Put the Hitch Pin and Hair Pin through the clevis.

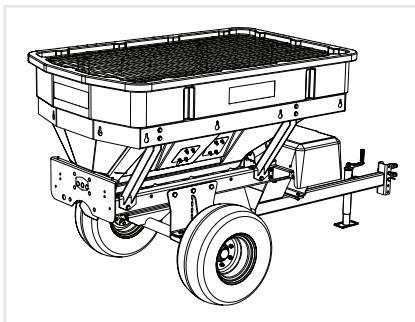

Assembly Instructions



STEP 9

Lower the tongue jack; pin in the vertical position. Remove the supports. Lower the spreader to rest on the tongue jack and the wheels.

STEP 10

Mount the fenders over the wheels.

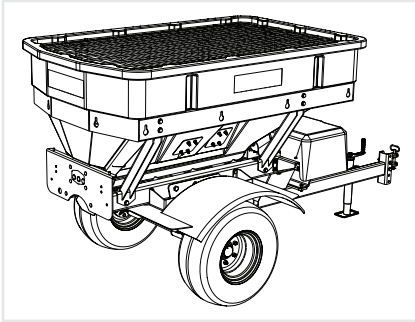

STEP 11

Attach the 'mud flap' to the rear of the fenders. Use the clamp plate on the outside of the mud flap.

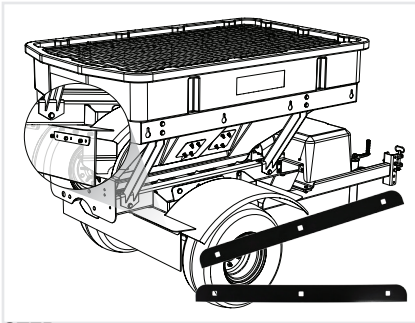

STEP 12

Attach the spinner drive: lower the drive onto the pegs at the rear of the frame; secure with the two bolts and nuts from the hardware kit through the hanger bracket. Plug it into the spinner plug on the side of the frame. Remove the bolt and nut from the spinner assembly's hub. Slide the hub through the bearing and over the shaft protruding from the drive enclosure. Align the holes in the hub and shaft; secure together with the bolt and nut removed earlier. Tighten the set screws on the bearing using threadlocker and an allen wrench.

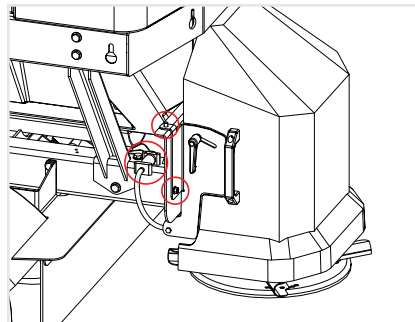
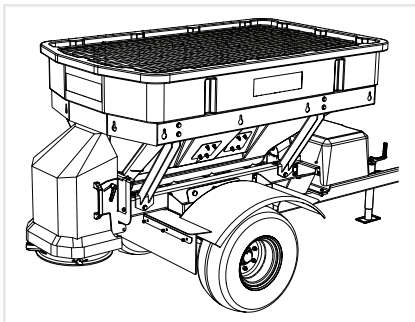

STEP 13

Install and connect batteries (under cover). **Batteries are not included with the spreader.** Use the long wires from T30725 to connect the batteries to each other. Use the short wires to connect to the control board: Red to "BAT +" and Black to "GROUND". Install the cover when finished.

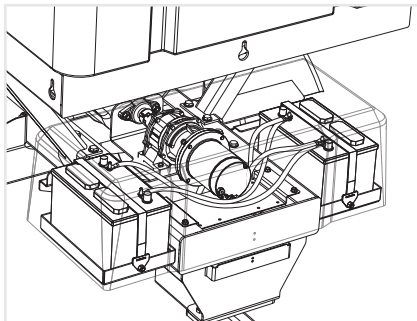

Owner must supply the batteries. They are not included with the spreader.

STEP 14

Fit Weather Cover over the top of the hopper.

FINISHED

STEP 1

Determine the location of the vehicle's battery.

STEP 2

Mount the breaker within 12 inches of the battery's positive terminal.

STEP 3

Route the harness from the rear of the vehicle, near the drawbar, to the battery. Leave enough harness free near the hitch to allow connecting to the trailer tongue plug. Keep away from high-temp and moving components

STEP 4

Connect the negative lead of the harness to the negative terminal of the battery and the positive harness lead to the "AUX" terminal on the breaker.

STEP 5

Tie the harness to the frame and other harnesses, working from the hitch area to the battery. Keep away from high-temperature and moving components. Leave the end by the hitch loose so the harness can connect to the plug on the trailer tongue.

STEP 6

Connect the breaker wire to the positive terminal of the battery and the "BAT" terminal of the breaker.

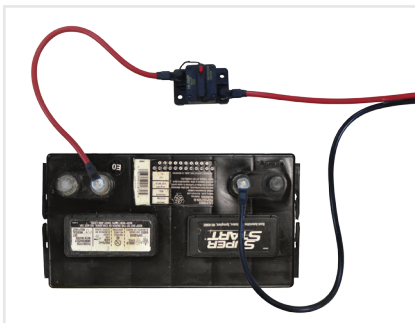

View of Battery, Breaker, Breaker Wire, and Harness.

STEP 7

Connect the spreader. Test that the spinner, auger, and vibrator work.

FINISHED