

Part Number : V100FP

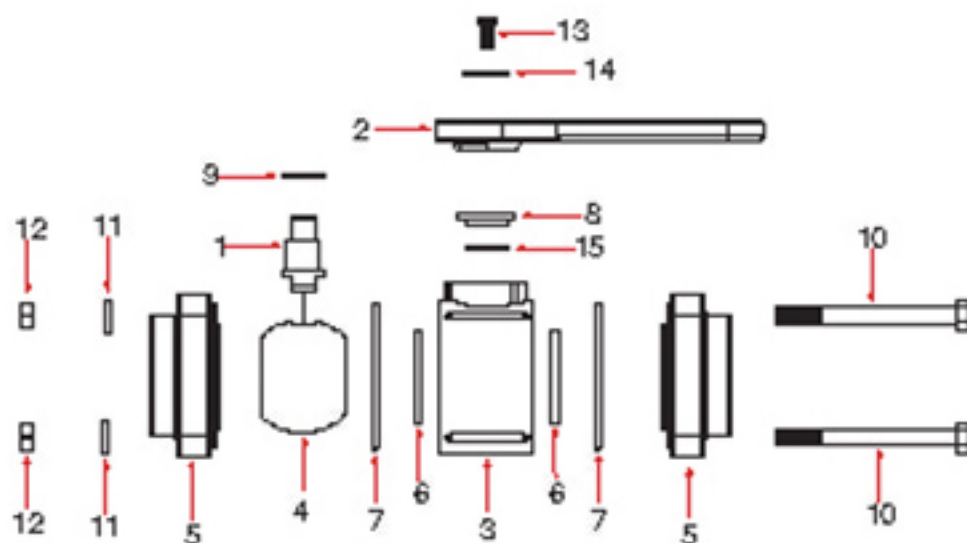

Item	Part No.	Description	Qty.
2	V10153A	Handle	1
3	V10254	Valve Body	1
4	V10155*	Valve Ball	1
5	V10257	1" Full Port End Plate	2
5	V10256	1¼" End Plate	2
6	V10258A*	Ball Seat	2
7	V10264	FKM (viton type) Valve Body O-Ring	2
8	V10159*	Upper Stem Bushing	1
9	V10060*	Thrust Washer	1
10	V10117	5/16" x 3½" SS Body Bolt	4
11	V10118	5/16" SS Lock Washer	4
12	V10119	5/16" SS Nut	4
13	V10020A	#10 x 1¼" SS Handle Bolt	1
14	V07021A	SS Handle Washer	1
15	V10163*	FKM (viton type) Stem O-Ring	1
1	V10151A	Stem	1

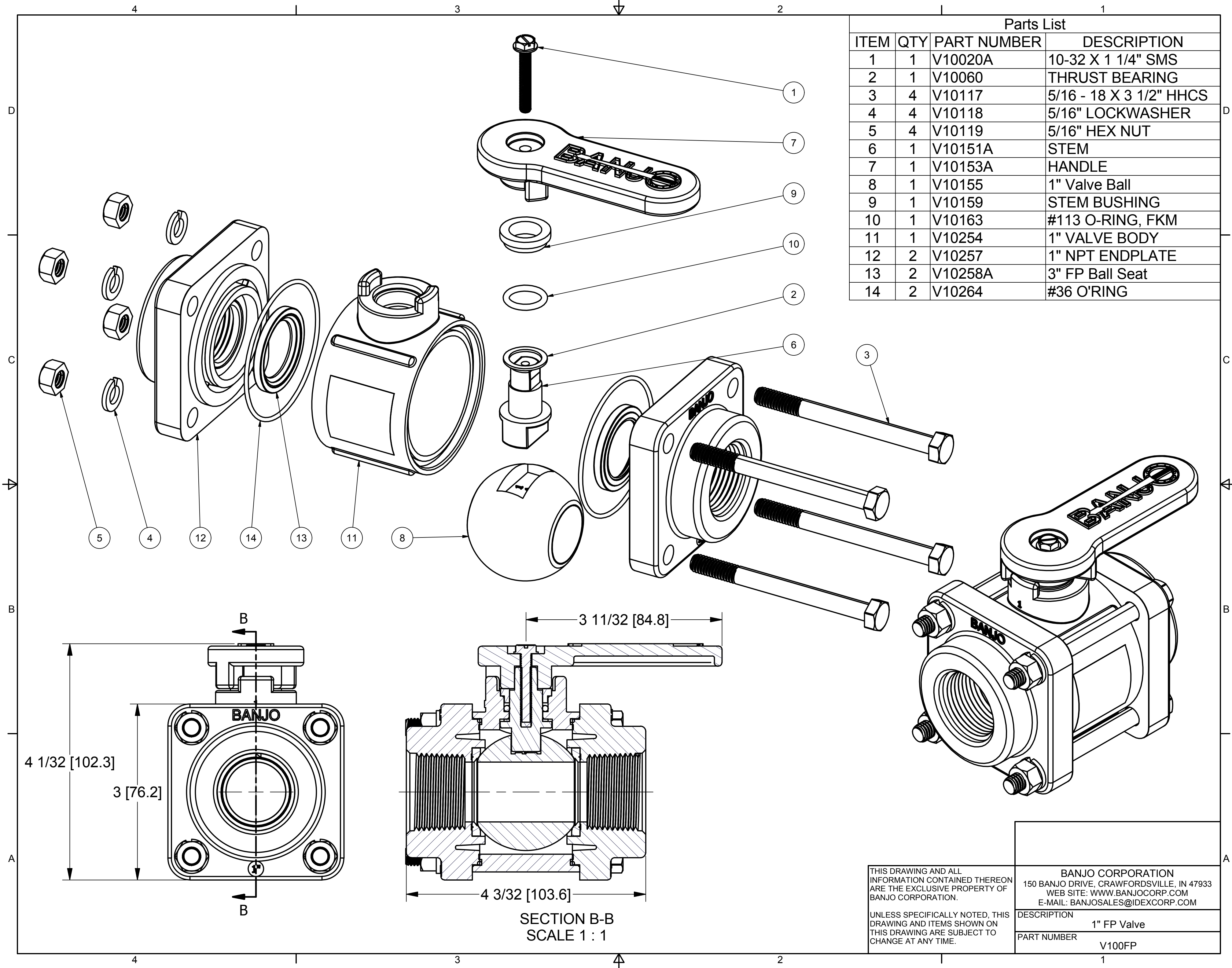

Parts List			
ITEM	QTY	PART NUMBER	DESCRIPTION
1	1	V10020A	10-32 X 1 1/4" SMS
2	1	V10060	THRUST BEARING
3	4	V10117	5/16 - 18 X 3 1/2" HHCS
4	4	V10118	5/16" LOCKWASHER
5	4	V10119	5/16" HEX NUT
6	1	V10151A	STEM
7	1	V10153A	HANDLE
8	1	V10155	1" Valve Ball
9	1	V10159	STEM BUSHING
10	1	V10163	#113 O-RING, FKM
11	1	V10254	1" VALVE BODY
12	2	V10257	1" NPT ENDPLATE
13	2	V10258A	3" FP Ball Seat
14	2	V10264	#36 O-RING

THIS DRAWING AND ALL INFORMATION CONTAINED THEREON ARE THE EXCLUSIVE PROPERTY OF BANJO CORPORATION.

UNLESS SPECIFICALLY NOTED, THIS DRAWING AND ITEMS SHOWN ON THIS DRAWING ARE SUBJECT TO CHANGE AT ANY TIME.

BANJO CORPORATION
 150 BANJO DRIVE, CRAWFORDSVILLE, IN 47933
 WEB SITE: WWW.BANJOCORP.COM
 E-MAIL: BANJOSALES@IDEXCORP.COM

DESCRIPTION 1" FP Valve
 PART NUMBER V100FP

SECTION B-B
 SCALE 1 : 1