



# High Pressure Diaphragm Pumps

Form L-1384  
12/11, Rev. B

## Installation, Operation, Repair and Parts Manual

### Description

Heavy-duty, high pressure diaphragm pumps. These industrial-built pumps are designed to handle all of your high pressure and volume diaphragm pump needs with minimal maintenance required. Their innovative, external manifold design allows for normal servicing to be done from one side of the pump, thereby eliminating the need

for dismounting. These pumps are excellent for chemical spraying where higher pressures are desired, such as insecticide spraying, air blast and tall tree sprayers. They also work great for high pressure cleaning and disinfecting applications, such as poultry house cleaners.

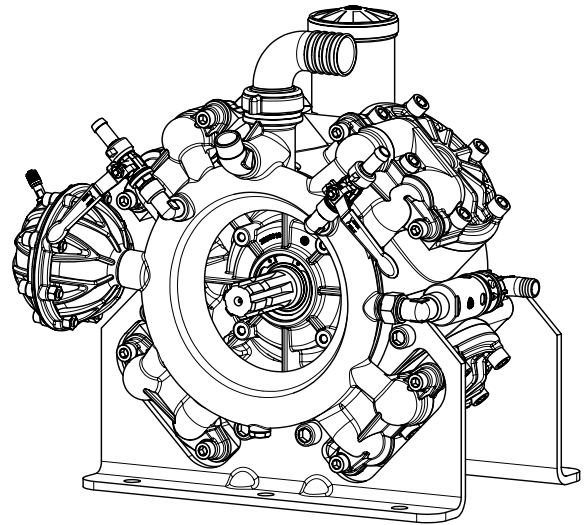
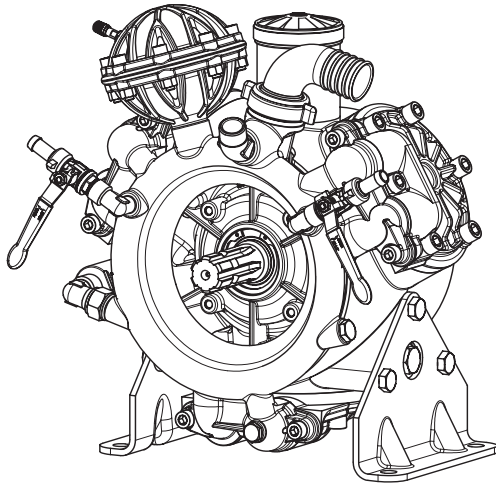

**Model 9910-DBS110**  
**Model 9910-DBA110**  
Max flow: 28.5 gpm  
Max pressure: 725 psi  
Max speed: 550 rpm  
3 Diaphragms

**Model 9910-DBS140**  
**Model 9910-DBA140**  
Max flow: 37.6 gpm  
Max pressure: 725 psi  
Max speed: 550 rpm  
3 Diaphragms

**Model 9910-DBS160**  
**Model 9910-DBA160**  
Max flow: 39.7 gpm  
Max pressure: 725 psi  
Max speed: 550 rpm  
4 Diaphragms

**Model 9910-DBS200**  
**Model 9910-DBA200**  
Max flow: 49.8 gpm  
Max pressure: 725 psi  
Max speed: 550 rpm  
4 Diaphragms

### Control Units 9910-GH50 & 9910-BMH50

Control units are available for easy flow and pressure control of your sprayer system. These units include a pressure relief valve to control pressure, an oil-filled pressure gauge to monitor pressure, and an outlet valve to control flow. Control unit 9910-BMH50 can be remote mounted with Kit No. 9910-KIT999. Refer to the adjoining chart to select the proper control unit for your pump.

Control Unit Model	Max. GPM	Max. PSI	Pump Model
9910-GH50	51	725	All models
9910-BMH50	41	725	All 110,140 and 160 Series

## General Safety Information

### **[NOTE]**

Notes are used to notify of installation, operation, or maintenance information that is important but not safety related.

### **[CAUTION]**

Caution is used to indicate the presence of a hazard, which will or can cause minor injury or property damage if the notice is ignored.

### **[WARNING]**

**Warning denotes that a potential hazard exists and indicates procedures that must be followed exactly to either eliminate or reduce the hazard, and to avoid serious personal injury, or prevent future safety problems with the product.**

### **[DANGER]**

Danger is used to indicate the presence of a hazard that will result in severe personal injury, death, or property damage if the notice is ignored.

### **[DANGER]**

- Do not pump flammable or explosive fluids such as gasoline, fuel oil, kerosene, etc. Do not use in explosive atmospheres. Do not pump asphalt sealer, roofing compounds, concrete sealers, or any two-step curing products. The pump should only be used with liquids compatible with the pump materials. Failure to follow this notice can result in severe personal injury and/or property damage and will void the product warranty.
- Never use your hand to check the condition of hydraulic lines or hoses. If hydraulic fluid penetrates the skin, get medical attention immediately. Failure to get proper medical attention may result in loss of limb or life. The safest way to check hydraulic lines is by holding a piece of cardboard next to the hydraulic line or hose.

### **[WARNING]**

- The sound pressure level of the pump may exceed 80dBA. Observe all safety precautions when operating the pump within close proximity for extended periods by wearing hearing protectors. Extended exposure to elevated sound levels will result in permanent loss of hearing acuteness, tinnitus, tiredness, stress, and other effects such as loss of balance and awareness.
- Verify that pump shaft rotates freely prior to engaging the pump drive.

### **[CAUTION]**

- Do not pump at pressures higher than the maximum recommended pressure.
- Operate the pump between a temperature range of 45° to 140° F [7° to 60° C].
- Make certain that the power source conforms to the requirements of your equipment.
- Provide adequate protection in guarding around the moving parts such as shafts and pulleys.
- Disconnect the power before servicing.
- Release all pressure within the system before servicing any component.
- Drain all liquids from the system before servicing.
- Secure the discharge line before starting the pump. An unsecured discharge line may whip, resulting in personal injury and/or property damage.
- Check all hoses for weak or worn condition before each use. Make certain that all connections are tight and secure.
- Periodically inspect the pump and the system components. Perform routine maintenance as required (See Maintenance).
- When wiring an electrically-driven pump, follow all electrical and safety codes, as well as the most recent National Electrical Code (NEC) and the Occupational Safety and Health Act (OSHA) requirements.
- Use only pipe, hose, and hose fittings rated for maximum rated pressure of the pump or the pressure at which the pressure relief valve is set at. Do not use used pipe.
- Do not use these pumps for pumping water or other liquids for human or animal consumption.
- Do not pressure feed pump inlet.

## Installation

**NOTE:** Use only pipe, fittings, accessories, hose, etc. rated for the maximum pressure rating of the pump.

1. Always mount the pump with oil sight tube in the upright position.
2. The correct type and size of hose is vital to good performance:
  - a. Use good quality inlet hose, compatible with fluids being pumped and with good elasticity to reduce inlet water hammer or pulsation. Be sure that the hose is not too rigid but capable of operating at low vacuums without collapsing. The diameter of the inlet hose should be at least that of the pump inlet port size and preferably one size larger if the inlet line is longer than approximately 6 feet.
  - b. Use only approved high pressure hose on the discharge side of the pump.
3. Most ports are provided with hose barb connections. Use good quality hose clamps and tighten securely.
4. See the figure for typical system hook-up. The diagram shows necessary components and accessories and their connections within the complete system.

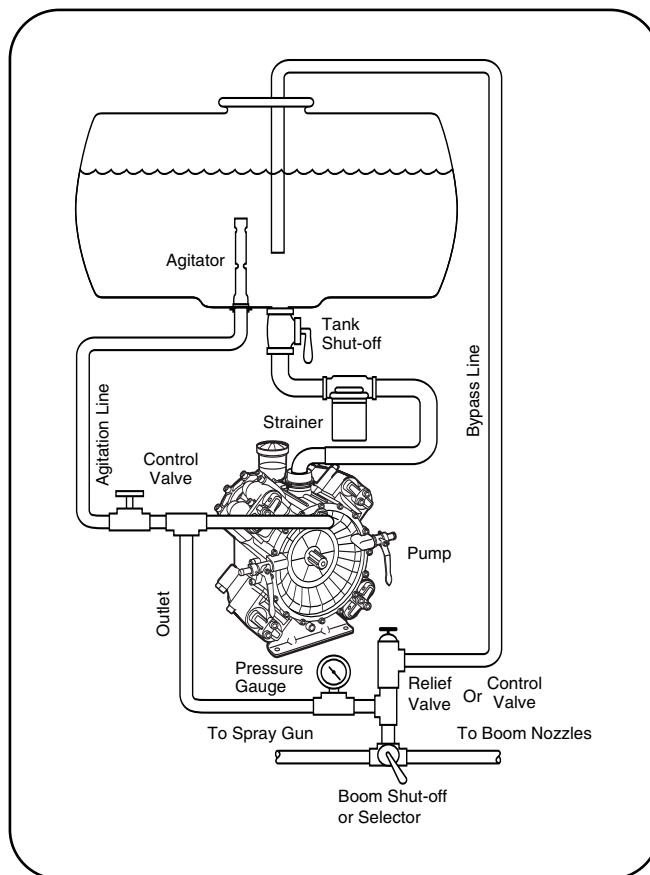

## Pump Operation Instructions

1. Be sure the oil is halfway up the clear oil sight tube. If necessary, fill to the correct level with Hypro Oil (Part Number 2160-0038). Hypro Oil is a specially formulated, high-grade, nondetergent, SAE 30 weight oil designed to prolong pump life.
2. Make sure the suction hose barb is tightly screwed onto the suction union, and that there are no air leaks on the inlet side of the pump.
3. Check the charge pressure on the pulsation dampener before starting the pump. The pressure is checked with a standard automotive air gauge. The pressure should be at approximately 20% of your operating spray pressure.
4. The relief valve bypass port should be connected back to the liquid tank unrestricted. Do not hook the bypass line back to the inlet port or inlet hose.
5. Always allow the pump to start under low pressure by putting the pressure release lever in the up position.
6. Start the pump and run for approximately one minute at low pressure. Stop the pump and check the oil level in sight glass. Oil should be halfway up the sight glass. Add Hypro Oil (Part Number 2160-0038) if necessary. See chart below for approximate oil capacities.
7. Return the pressure release lever to the pressure position and adjust the pump to the desired pressure by changing the relief valve setting on the control unit, relief valve, or unloader.

<b>Crankcase Oil Capacities</b>	
110/140 Series	2 qts. 19.7 oz. (83.7 oz.)
160/200 Series	2 qts. 30 oz. (94 oz.)

## Troubleshooting

Symptom	Probable Cause(s)	Corrective Action
The pump does not draw water.	One or more valves are seating improperly.	Remove valve and check for debris.
	Suction line is plugged or collapsed. Clogged strainer.	Examine suction line. Clean strainer.
The liquid flow is irregular.	The charge in the pulsation damper is incorrect.	Check pressure in pulsation damper (approximately 20% of your operating spray pressure).
	One or more valves are seating improperly.	Remove valve and check for debris. Examine the valve seatings and clean them.
Output drops and the pump is noisy.	Oil level is too low.	Add oil to correct level (halfway up the sight tube).
Oil comes out of the discharge port or oil is a milky color.	One or more diaphragms split.	Remove manifold and heads. Drain oil and clean crankcase of water. Replace diaphragms, heads and manifold. Refill with Hypro Oil (Part No. 2160-0038).

## Hazardous Substance Alert

- Always drain and flush pump before servicing or disassembling for any reason (see instructions).
- Always drain and flush pump prior to returning unit for repair.
- Never store pumps containing hazardous chemicals.
- Before returning pump for service/repair, drain out all liquids and flush unit with neutralizing liquid. Then, drain the pump. Attach tag or include written notice certifying that this has been done. Please note that it is illegal to ship or transport any hazardous chemicals without United States Environmental Protection Agency Licensing.

## Maintenance Schedule

REGULAR SERVICE PERIOD		First Use	Each Use	First month or 40 hours	Every 3 months or 500 hours	Every 6 months or 1000 hours
Performed at every indicated month or operating hour interval, whichever comes first.						
Item						
Crankcase Oil	Check Level	X	X			
	Replace			X	X	
Gearbox Oil	Check Level	X	X			
	Replace			X	X	
Pulsation Dampener Pressure (in models with dampeners)	Set to 20% of working PSI	X				
	Check			X	X	
Diaphragms	Replace				X	
	Check				X	
Valves	Replace					X
	Check				X	
O-rings	Replace					X
	Check				X	

## Maintenance Instructions for All Models

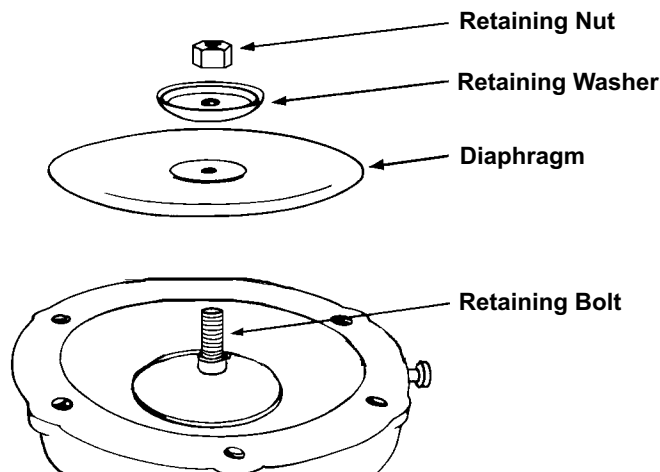

1. After usage, flush the pump with clean water.
2. Hypro diaphragm pumps come with oil in the crankcase. **Hypro recommends changing oil after 40 hours of break-in operation and every three months or 500 hours, whichever comes first. Use Hypro Oil (Part Number 2160-0038).** Hypro Oil is a specially formulated, high-grade, nondetergent, SAE 30 weight oil designed to prolong pump life. To drain oil from the pump, remove the oil drain plug, located on the side of the pump body for series 110 and 140 and underneath the pump body for series 160 and 200. To fill the pump with oil, slowly pour oil into sight tube while turning the pump shaft. Turning the pump shaft purges all the air out of the crankcase. Always change oil when replacing diaphragms.
3. For winter storage or if a freezing condition will be encountered, flush pump with a 50/50 mixture of water and antifreeze.

### Diaphragm and Valve Replacement for All Models

#### I. Valve and O-Ring Replacement

Occasionally debris can cause the valves to not seat properly or damage the o-rings. To check for this problem, follow these steps.

1. Remove valve retainers and valve holders. With holders removed, the valves can be readily removed and checked for debris or wear. Check o-rings as well. See the parts list for appropriate valve and o-ring kits.
2. Replace the necessary parts and reassemble.

#### II. Diaphragm Replacement

Change diaphragms every 500 hours or three months, whichever comes first.

1. Drain the oil from the pump by removing the cap from oil sight tube and removing the oil drain plug. Rotate the shaft to remove excess oil.
2. Remove the head bolts and heads.
3. Turn the crankshaft to bring the retaining bolt as far out as possible.
4. Use a 13 mm box wrench to remove the diaphragm retaining nut. Remove the nut, retaining washer and diaphragm.
5. When reinstalling, turn the crankshaft to bring the piston to its downstroke and seat the new diaphragm into the sleeve groove. Install the retaining washer and tighten the nut. Clean any excess oil from the area. Install the new port o-rings. Install the heads and tighten the bolts.
6. Replace the pulsation dampener diaphragm by first bleeding the air from the dampener. Remove the cover holding the dampener assembly together, then replace the diaphragm. See Pump Operation Instructions on page 3, Ref. Number 3.
7. Refill the crankcase with Hypro Oil (Part Number 2160-0038). Rotate the shaft to distribute the oil and fill to the proper level.

## Control Unit 9910-GH50

The Model 9910-GH50 Control Unit is designed for the control of pressure up to 725 psi and flows up to 51 gpm. It consists of an adjustable pressure relief valve, pressure gauge, and a manual pressure release lever.

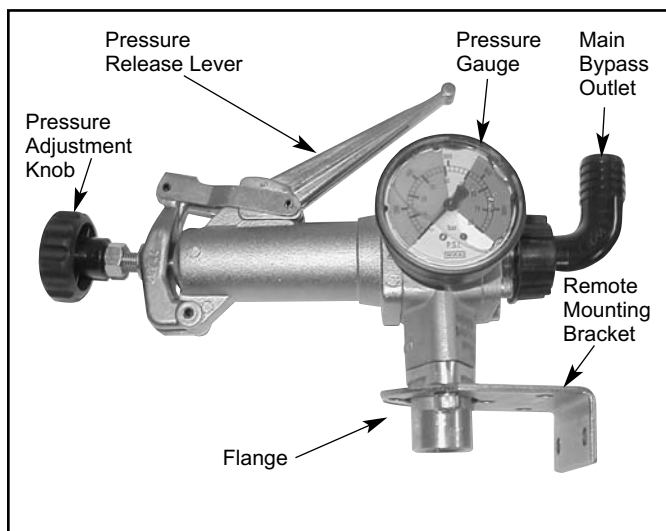

## Installation

### Direct Mounting:

1. Remove the two Allen bolts (Ref. 23)\* from the flange (Ref. 24)\* on the control unit. Retain the bolts for later. Do not misplace the o-ring.
2. Locate the outlet elbow (Ref. 52)\*\* on the top of the discharge manifold of the pump.
3. Using thread sealant, attach the flange onto the outlet elbow. Tighten the flange to the desired orientation.
4. Verify o-ring is in place on the flange. Place the control unit onto the flange in the desired orientation, and replace and tighten the bolts previously removed in step 1.
5. Connect the bypass hose to the bypass port hose barb (Ref. 38)\* and run it unrestricted back to the tank.
6. Connect the desired amount of lines to the outlet port hose barbs (Ref. 42)\*\*. Unused ports can be shut off with the ball valve, or they can be plugged.

\* Refer to diagram on page 7.

\*\* Refer to diagram on page 10 or 12.

### Remote Mounting:

1. Remove the two Allen bolts (Ref. 23)\* from the flange on the control unit.
2. Position the mounting bracket (Ref. 66)\* over the flange in the desired position. Replace and secure bolts.
3. With high pressure hose, connect the NPT flange on the control unit to the NPT elbow at the top of the discharge manifold of the pump.
4. Connect the bypass hose to the bypass port hose barb (Ref. 38)\* and run it unrestricted back to the tank.
5. Connect the desired amount of lines to the outlet port hose barbs (Ref. 42)\*\*. Unused ports can be shut off with the ball valve, or they can be plugged.

**NOTE: For all discharge connections, use hose rated equal to or greater than the maximum pressure rating of the pump.**

## Operation

1. Refer to the pump operation instructions for proper operation of the pump.
2. The control unit can be put into full bypass mode by lifting the pressure release lever into the up position.
3. With the pressure release lever in the down (pressure) position, pressure can be controlled with the adjustment knob at the end of the relief valve. Turning it clockwise will increase the operating pressure and turning it counterclockwise will decrease the pressure.
4. Flow can be controlled with the ball valves on each of the outlet ports.

## Parts List for Control Unit 9910-GH50

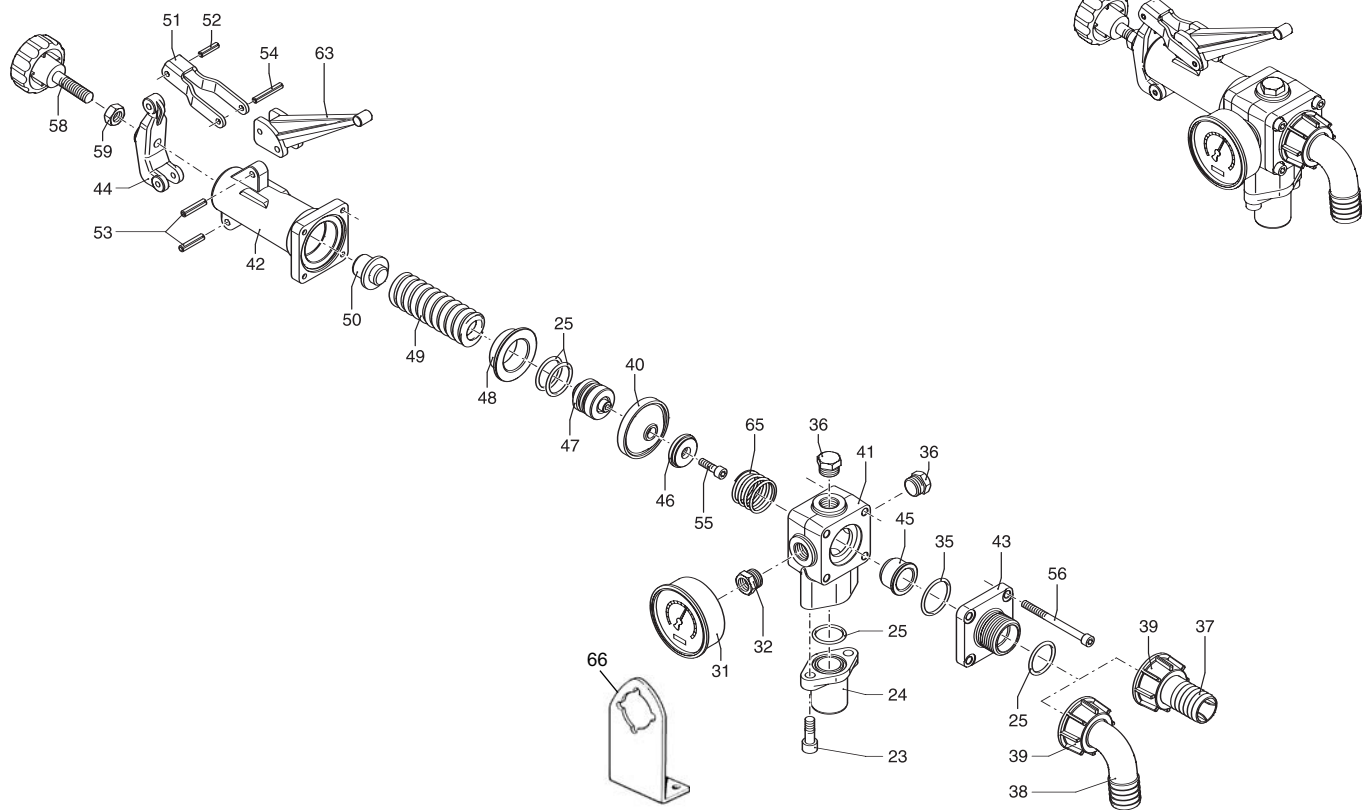

REF. NO.	PART NUMBER	DESCRIPTION	QTY. REQ'D
23	9910-620610	M8x30 Bolt	2
24	9910-550394	Flange 3/4" G(F)	1
25	9910-550350	O-Ring	4
31	9910-1880290	Pressure gauge	1
32	9910-130170	Pipe reducer	1
35	9910-280220	O-Ring	1
36	9910-130171	Plug	2
37	9910-550210	Hose barb (Optional)	1
38	9910-550370	Elbow (Standard)	1
39	9910-550242	Ring Nut	1
40	9910-390740	Diaphragm (Buna)	1
41	9910-680412	Valve body	1
42	9910-680423	Upper valve side	1
43	9910-680432	Discharge flange	1
44	9910-680442	Tension adj. support	1
45	9910-680460	Valve seat	1
46	9910-680470	Valve	1
47	9910-680480	Valve piston	1
48	9910-680490	Piston valve	1
49	9910-680500	Regulating spring	1
50	9910-680510	Spring guide	1
51	9910-680520	Lever guide	1
52	9910-680530	Pin	1
53	9910-680540	Pin	2
54	9910-680550	Pin	1
55	9910-680700	M6x20 Bolt	1
56	9910-680570	M6x60 Bolt	4
58	9910-660130	Control knob	1
59	9910-180150	Nut	1
63	9910-680452	Control lever	1
65	9910-320420	Spring	1
66	9910-1150590	Remote mounting bracket*	1

9910-KIT1936 Repair Kit	
REF. NO.	QTY.
25	4
35	1
38	1
40	1
45	1
46	1
65	1

\* Order separately

## Control Unit 9910-BMH50

The Model 9910-BMH50 Control Unit is designed for the control of pressure up to 725 psi and flows up to 41 gpm. It consists of an adjustable pressure relief valve, pressure gauge, and a manual pressure release lever.

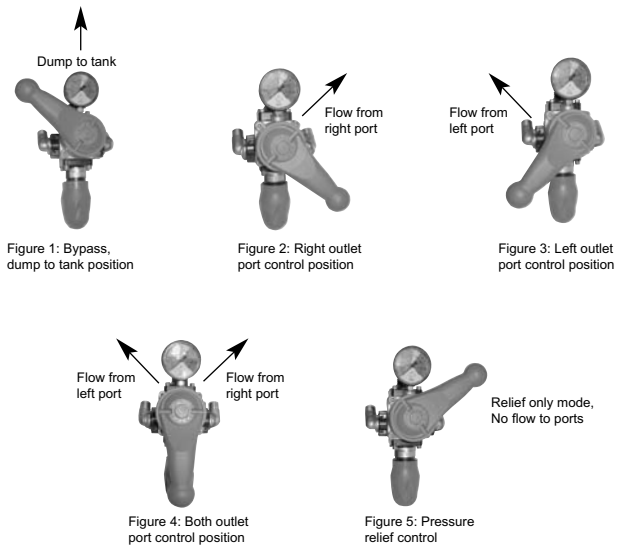
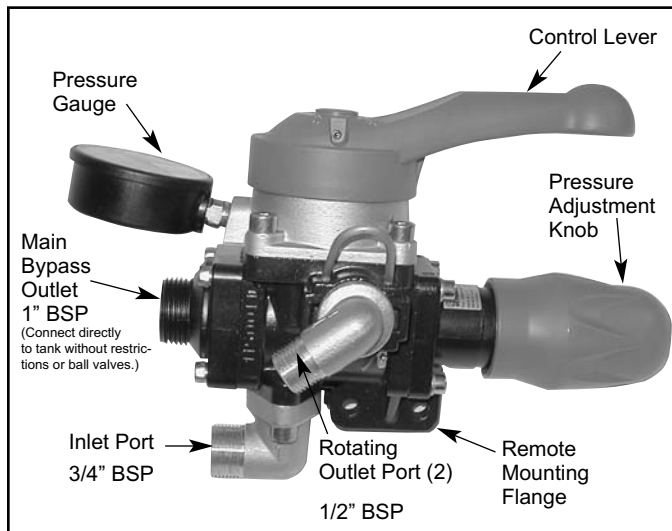

## Installation

### Direct Mounting:

1. If the red plastic shield (Ref. 51)\*\* is installed, remove it by removing the four Allen bolts from the inside of the shield. Locate the outlet elbow (Ref. 52)\*\* on the top of the discharge manifold of the pump and remove it.
2. Remove the two Allen bolts (Ref. 45)\* from the adapter elbow flange (Ref. 15)\* on the control unit. Retain the bolts for later. Do not misplace the o-ring.
3. Using thread sealant, attach the adapter elbow flange to the port where the outlet elbow was removed. Tighten the flange to the desired orientation.
4. Verify o-ring is in place on the flange. Place the control unit onto the flange in the desired orientation, and replace and tighten the bolts previously removed in step 2.
5. Connect the bypass hose to the bypass port fitting (not supplied) or purchase part separately (Ref. 55)\* and run line unrestricted back to the tank.
6. Connect the desired amount of lines to the outlet port hose barbs (Ref. 42)\*\*. Unused ports can be shut off with the ball valve, or they can be plugged.

### Remote Mounting: (Use Kit No. 9910-KIT999)

1. Attach remote mounting bracket to the mounting flange on the control unit using the two Allen bolts (Ref. 59)\* and nuts (Ref. 61)\* in Kit No. 9910-KIT999.
2. Connect hose barb fitting included in Kit 9910-KIT999 to the bypass outlet of the control unit. Ensure the o-ring is in place.
3. With high pressure hose, connect the adapter elbow flange on the control unit to the NPT elbow at the top of the discharge manifold of the pump.
4. Connect the bypass hose to the bypass port hose barb (Ref. 38)\* and run it unrestricted back to the tank.
5. Connect the desired amount of lines to the outlet port hose barbs (Ref. 42)\*\*. Unused ports can be shut off with the ball valve, or they can be plugged.

**NOTE: For all discharge connections, use hose rated equal to or greater than the maximum pressure rating of the pump.**

\* Refer to diagram on page 9.

\*\* Refer to diagram on page 10 or 12.

## Operation

1. Refer to the pump operation instructions for proper operation of the pump.
2. The control unit can be put into full bypass mode by rotating the control lever to the 10:30 position such that the word "BYPASS" is aligned to the pressure adjustment knob. See Figure 1.
3. To control to just the right outlet port, rotate the control lever to the 4:30 position such that the letters "SX" are aligned to the pressure adjustment knob. See Figure 2.
4. To control to just the left outlet port, rotate the control lever to the 7:30 position such that the letters "DX" are aligned to the pressure adjustment knob. See Figure 3.
5. To control both booms, rotate the control lever to the 6:00 position such that the letters "SX-DX" and the control lever are aligned to the pressure adjustment knob. See Figure 4.
6. To maintain pressure control on the pump without flow to either outlet port, rotate the control lever to the 2:30 position such that the word "PRESS" is aligned with the pressure adjustment knob. See Figure 5.
7. Pressure can be controlled with the adjustment knob at the end of the relief valve. Turning it clockwise will increase the operating pressure and turning it counterclockwise will decrease the pressure.



# Parts List for Control Unit 9910-BMH50

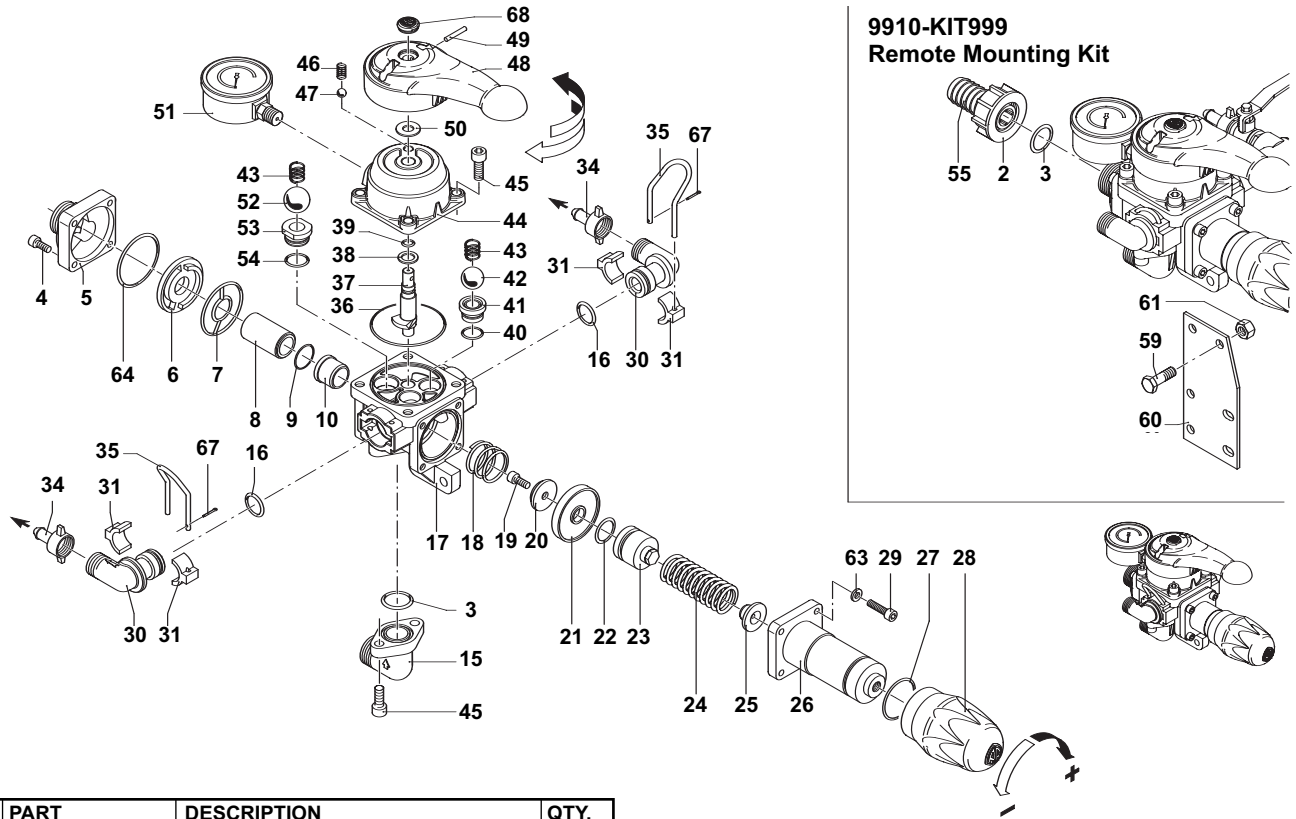

REF. NO.	PART NUMBER	DESCRIPTION	QTY. REQ'D
1	9910-550370	Elbow	1
2	9910-550242	Ring nut	1
3	9910-550350	O-Ring	2
4	9910-780060	Bolt	4
5	9910-1150031	Bypass Flange 1" BSP	1
6	9910-1150021	Spacer	1
7	9910-1150041	Gasket	1
8	9910-1150050	Spacer	1
9	N/A	O-Ring	1
10	9910-1150060	Valve seat	1
15	9910-1150880	Inlet Adapter 3/4" BSP	1
16	9910-390060	O-Ring	2
17	9910-1150012	Valve body	1
18	9910-320420	Spring	1
19	9910-680700	Bolt	1
20	9910-1150070	Valve	1
21	9910-1150130	Diaphragm (Desmopan) Standard	1
21	9910-1150131	Diaphragm (Buna) Optional	1
22	9910-660160	O-Ring	1
23	9910-1150180	Piston	1
24	9910-1150190	Spring	1
25	9910-1150200	Spring plate	1
26	9910-1150171	Spring guide body	1
27	9910-820490	O-Ring	1
28	9910-1150920	Knob	1
29	9910-1040370	Bolt	4
30	9910-1150910	Outlet Adapter 1/2" BSP	2
31	9910-1150150	Clamp	4
34	9910-110130	1/2" Hose barb	2
35	9910-1040690	Retainer clip	2
36	9910-1150250	O-Ring	1
37	9910-1150120	Selector	1
38	9910-850720	Washer	1
39	9910-390340	O-Ring	1
40	9910-740290	O-Ring	2
41	9910-850650	Seat	2
42	9910-850660	Ball	2
43	9910-850680	Spring	3
44	9910-1150900	Upper body	1
45	9910-320360	Bolt	6
46	9910-850830	Spring	1

REF. NO.	PART NUMBER	DESCRIPTION	QTY. REQ'D
47	9910-621160	Ball	1
48	9910-1150890	Lever	1
49	9910-480520	Pin	1
50	9910-391460	Washer	1
51	9910-550545	Pressure gauge	1
52	9910-1150100	Ball	1
53	9910-1150091	Bypass seat	1
54	9910-880270	O-Ring	1
55	9910-550210	Hose barb	1
59	9910-180370	Bolt	2
60	9910-850690	Bracket	1
61	9910-390270	Nut	2
63	9910-550331	Washer	4
64	9910-1150280	O-Ring	1
65	9910-1150690	Elbow	1
67	9910-1040950	Split pin	2
68	9910-1150930	Lever plug	1

### 9910-KIT2464 Repair Kit

REF. NO.	QTY.
3	2
9	1
10	1
13	1
16	4
20	1
21	1
22	1
27	1
36	1
39	1
40	2
48	1
54	1
64	1

### 9910-KIT999 Remote Mounting Kit

REF. NO.	QTY.
2	1
3	1
55	1
59	2
60	1
61	2

# Parts Illustrations for Models 9910-DBS110 and 9910-DBS140

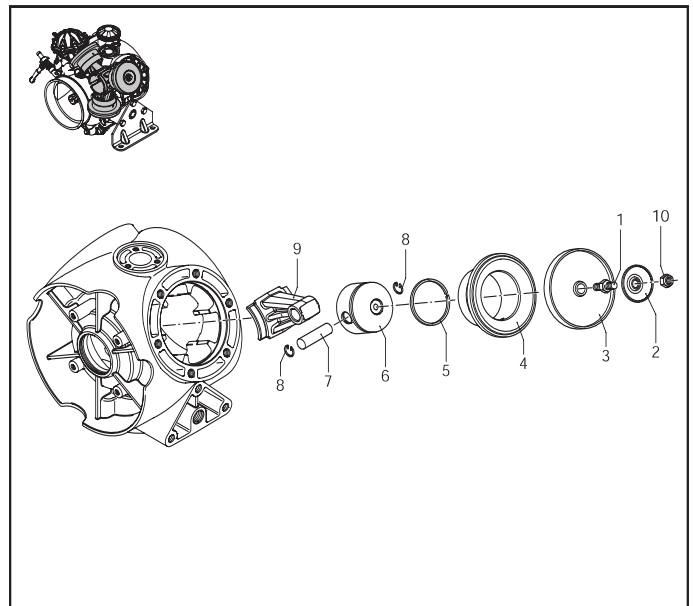
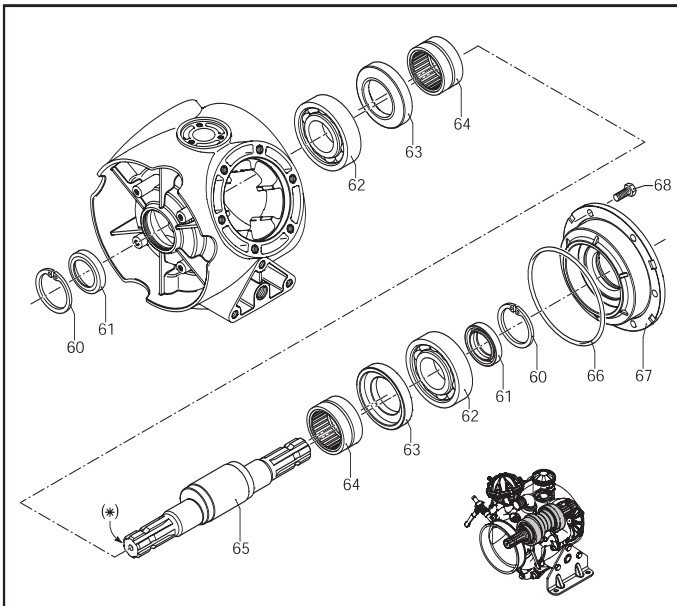
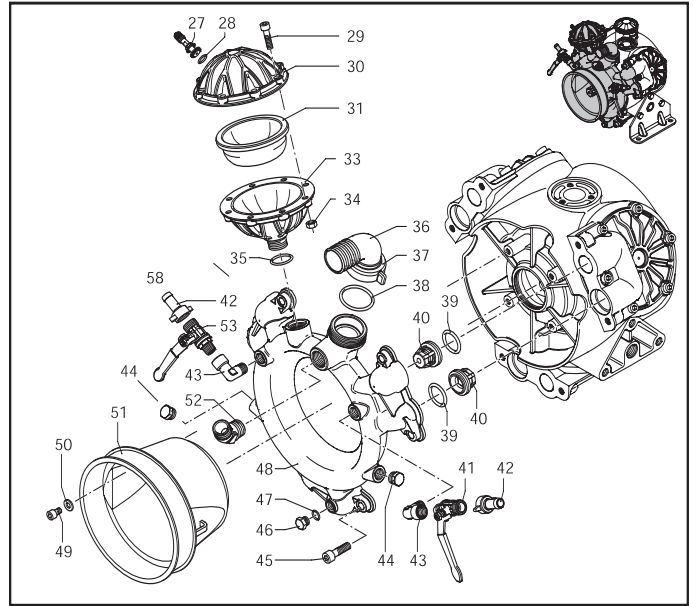
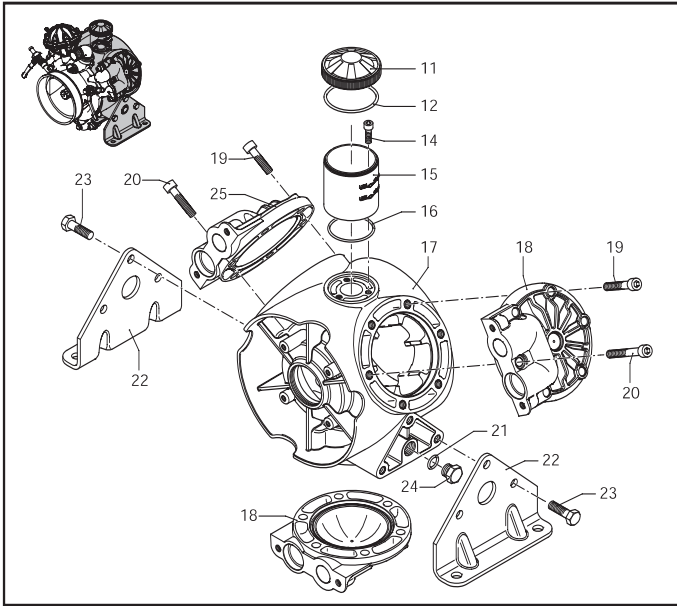

**NOTE:** From manifold side, heads on right side are marked with a "D" (#18) and heads on left side are marked with an "S" (#25).

## Parts List for Models 9910-DBS110 and 9910-DBS140

REF. NO.	PART NUMBER	DESCRIPTION	QTY. REQ'D
1	9910-2240100	Diaphragm pin	3
2	9910-580090	Retaining washer	3
3	9910-2240080	Diaphragm, Buna	3
4	9910-2240510	Sleeve DBS-110	3
4	9910-2240520	Sleeve DBS-140	3
5	9910-260230	Piston ring DBS-110	3
5	9910-2240360	Piston ring DBS-140	3
6	9910-2240060	Piston DBS-110	3
6	9910-2240350	Piston DBS-140	3
7	9910-260700	Piston pin DBS-110	3
7	9910-540070	Piston pin DBS-140	3
8	9910-160691	Pin ring	6
9	9910-2240090	Connecting rod	3
10	9910-2240110	Nut	3
11	9910-1800060	Black cap DBS-110	1
11	9910-750050	Red cap DBS-140	1
12	9910-1040060	O-Ring	1
14	9910-540290	M8x25 Bolt	3
15	9910-2240070	Oil sight glass	1
16	9910-2240270	O-Ring	1
17	9910-2240010	Pump body DBS-110	1
17	9910-2240011	Pump body DBS-140	1
18	9910-2240030	Right head (D)	2
19	9910-2240180	M12x50 Bolt	15
20	9910-2240220	M12x65 Bolt	3
21	9910-180101	O-Ring	2
22	9910-2240190	Base	2
23	9910-540100	M12x40 Bolt	6
24	9910-820361	Plug	2
25	9910-2240031	Left head (S)	1
27	9910-180020	Air valve	1
28	9910-650542	Gasket	1
29	9910-680350	M8x35 Bolt	8
30	9910-2240300	Upper air chamber	1
31	9910-550190	Diaphragm, Buna	1
33	9910-2240310	Lower air chamber	1
34	9910-380240	Nut	8
35	9910-720030	O-Ring	1
36	9910-2240210	Elbow 1-1/2"	1
37	9910-2240200	Ring nut	1
38	9910-390210	O-Ring	1
39	9910-680070	O-Ring	6
40	9910-759051	Complete valve	6
41	9910-130491	Right valve	1
42	9910-110130	Hose barb 1/2"	2
43	9910-2240260	Valve elbow	2
44	2406-0023	Plug	2
45	9910-650330	M10x35 Bolt	6

REF. NO.	PART NUMBER	DESCRIPTION	QTY. REQ'D
46	9910-880581	Cap, brass	1
47	9910-820510	O-Ring	1
48	9910-2240040	Manifold	1
49	9910-850250	M8x12 Bolt	4
50	9910-390311	Washer	4
51	9910-1500470	Shield	1
52	9910-851650	Outlet elbow	1
53	9910-KIT2497	Left valve	1
54	9910-881461	Threaded adapter	1
60	9910-2240160	Snap ring	2
61	9910-2240150	Seal ring	2
62	9910-2240430	Bearing	2
63	9910-2240121	Con rod ring	2
64	9910-850320	Roller bearing	2
65	9910-2240173	Crankshaft	1
66	9910-2240290	O-ring	1
67	9910-2240020	Flange	1
68	9910-160670	M10x25 Bolt	6



**9910-KIT2444  
Diaphragm Kit**

REF. NO.	QTY.
3	3

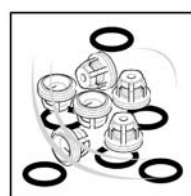

**9910-KIT2445  
Valve Kit**

REF. NO.	QTY.
39	6
40	6

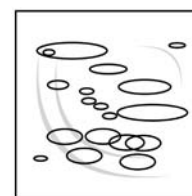

**9910-KIT2446  
O-Ring Kit**

REF. NO.	QTY.
12	1
16	1
21	2
35	1
38	1
39	6
47	1
66	1

REF. NO.	DESCRIPTION	Tightening Torque	
		In Lbs.	Nm
1	Dia. Pin	262.5	29.4
10	Nut	262.5	29.4
14	Bolt	87.5	9.8
19	Bolt	435.5	49.0
20	Bolt	435.5	49.0
23	Bolt	435.5	49.0
24	Plug	171.4	19.6
27	Air valve	34.5	3.9
29	Bolt	171.4	19.6
44	Plug	171.4	19.6
45	Bolt	350.0	39.2
46	Brass cap	171.4	19.6
49	Bolt	87.5	9.8
68	Bolt	350.0	39.2

# Parts Illustrations for Models 9910-DBS160 and 9910-DBS200

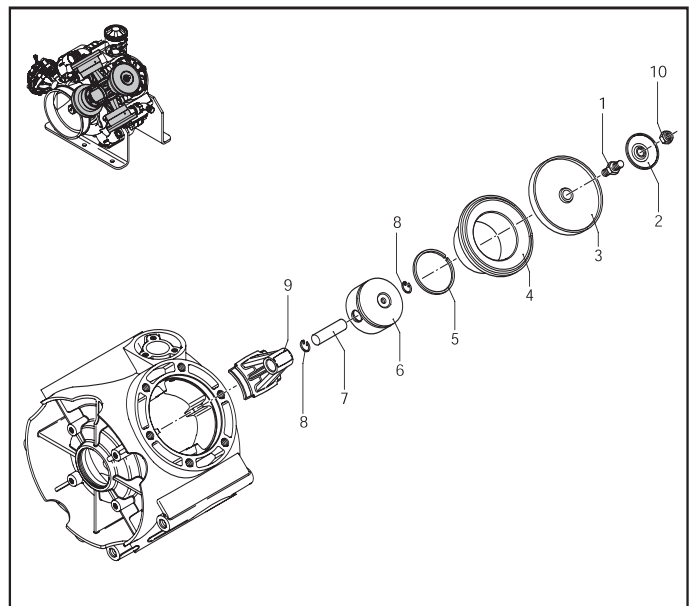
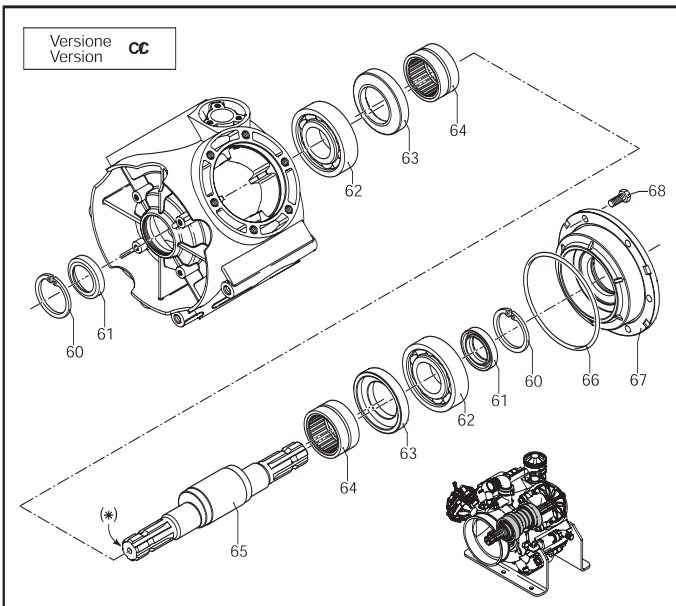
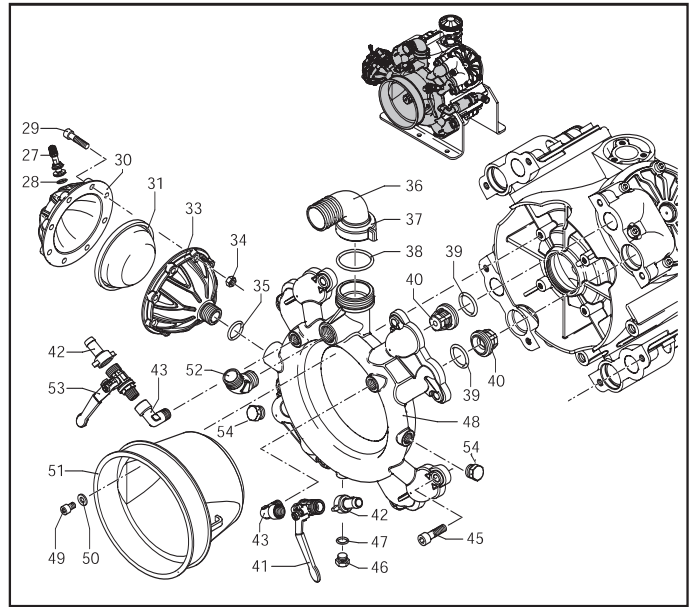
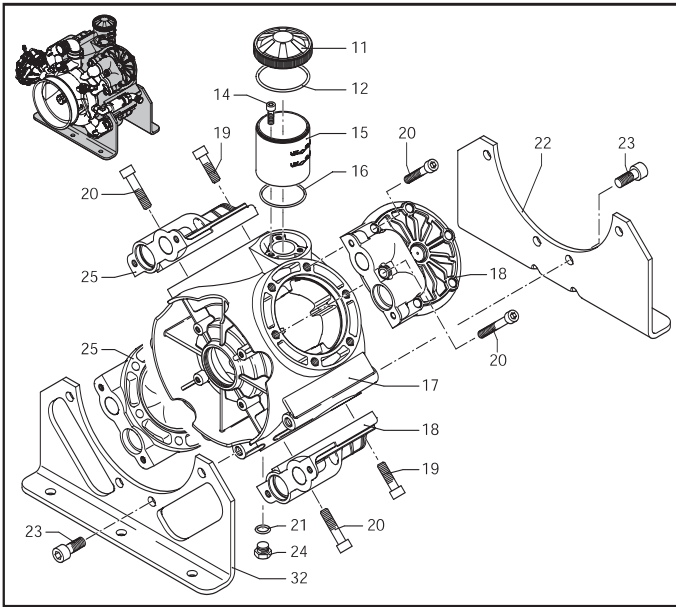

**NOTE:** From manifold side, heads on right side are marked with a "D" (#18) and heads on left side are marked with an "S" (#25).

## Parts List for Models 9910-DBS160 and 9910-DBS200

REF. NO.	PART NUMBER	DESCRIPTION	QTY. REQ'D
1	9910-2240100	Diaphragm pin	4
2	9910-580090	Retaining washer	4
3	9910-2240080	Diaphragm, Buna	4
4	9910-2240510	Sleeve DBS160	4
4	9910-2240520	Sleeve DBS200	4
5	9910-260230	Piston ring DBS160	4
5	9910-2240360	Piston ring DBS200	4
6	9910-2240060	Piston DBS160	4
6	9910-2240350	Piston DBS200	4
7	9910-260700	Piston pin DBS160	4
7	9910-540070	Piston pin DBS200	4
8	9910-160691	Pin ring	8
9	9910-2380050	Connecting rod	4
10	9910-2240110	Nut	4
11	9910-1800060	Black cap DBS160	1
11	9910-750050	Red cap DBS200	1
12	9910-1040060	O-Ring	1
14	9910-540290	M8x25 Bolt	3
15	9910-2240070	Oil sight glass	1
16	9910-2240270	O-Ring	1
17	9910-2380010	Pump body DBS160	1
17	9910-2380011	Pump body DBS200	1
18	9910-2240030	Right head (D)	2
19	9910-2240180	M12x50 Bolt	20
20	9910-2240220	M12x65 Bolt	4
21	9910-180101	O-Ring	1
22	9910-2380040	Base	1
23	9910-2380060	M14x35 Bolt	8
24	9910-820361	Plug	1
25	9910-2240031	Left head (S)	1
27	9910-180020	Air valve	1
28	9910-650542	Gasket	1
29	9910-680350	M8x35 Bolt	8
30	9910-2240300	Upper air chamber	1
31	9910-550190	Diaphragm, Buna	1
32	9910-2380030	Base	1
33	9910-2240310	Lower air chamber	1
34	9910-380240	Nut	8
35	9910-720030	O-Ring	1
36	9910-2240210	Elbow 1-1/2"	1
37	9910-2240200	Ring nut	1
38	9910-390210	O-Ring	8
39	9910-680070	O-Ring	8
40	9910-759051	Complete valve	8
41	9910-130491	Right valve	1

REF. NO.	PART NUMBER	DESCRIPTION	QTY. REQ'D
42	9910-110130	Hose barb 1/2"	2
43	9910-2240260	Valve elbow	2
45	9910-650330	M10x35 Bolt	8
46	9910-880581	Cap, brass	1
47	9910-820510	O-Ring	1
48	9910-2380020	Manifold	1
49	9910-850250	M8x12 Bolt	4
50	9910-390311	Washer	4
51	9910-1500470	Shield	1
52	9910-851650	Outlet elbow	1
53	9910-KIT2497	Left valve	1
54	2406-0023	Plug	1
60	9910-2240160	Snap ring	2
61	9910-2240150	Seal ring	2
62	9910-2240430	Bearing	2
63	9910-2240121	Con rod ring	2
64	9910-850320	Roller bearing	2
65	9910-2240173	Crankshaft	1
66	9910-2240290	O-ring	1
67	9910-2240020	Flange	1
68	9910-160670	M10x25 Bolt	6



9910-KIT2456 Diaphragm Kit	
REF. NO.	QTY.
3	4

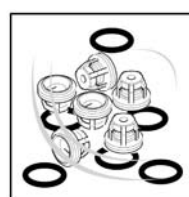

9910-KIT2374 Valve Kit	
REF. NO.	QTY.
39	8
40	8

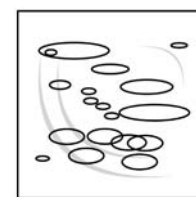

9910-KIT2457 O-Ring Kit	
REF. NO.	QTY.
12	1
16	1
21	1
35	1
38	1
39	8
47	1
66	1

REF. NO.	DESCRIPTION	Tightening Torque	
		In Lbs.	Nm
1	Dia. Pin	262.5	29.4
10	Nut	262.5	29.4
14	Bolt	87.5	9.8
19	Bolt	435.5	49.0
20	Bolt	435.5	49.0
23	Bolt	435.5	49.0
24	Plug	171.4	19.6
27	Air valve	34.5	3.9
29	Bolt	171.4	19.6
45	Bolt	350.0	39.2
46	Brass cap	171.4	19.6
49	Bolt	87.5	9.8
54	Plug	171.4	19.6
68	Bolt	350.0	39.2

# Parts Illustrations for Models 9910-DBA110 and 9910-DBA140

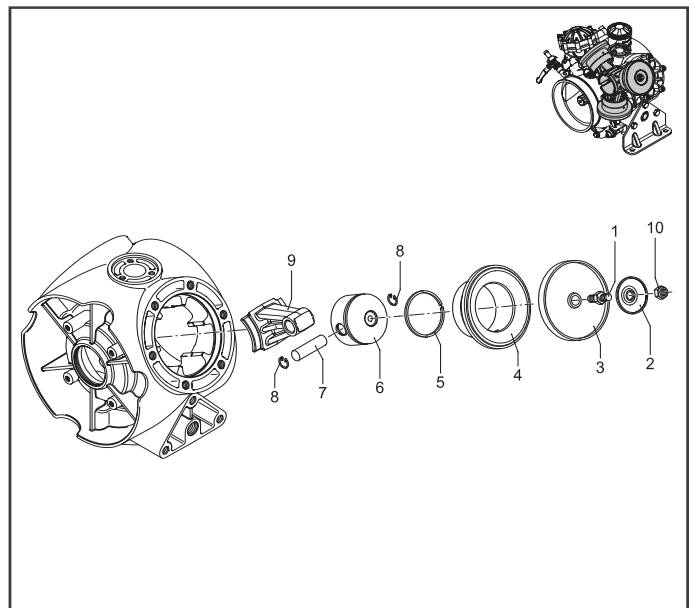
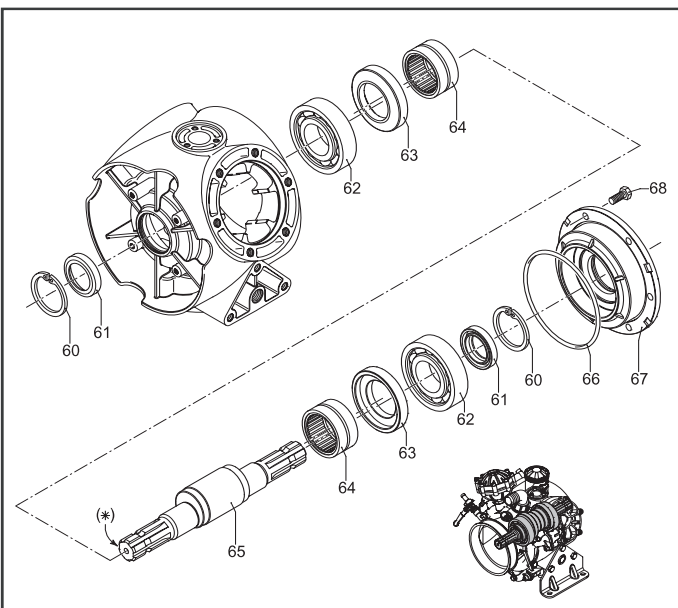
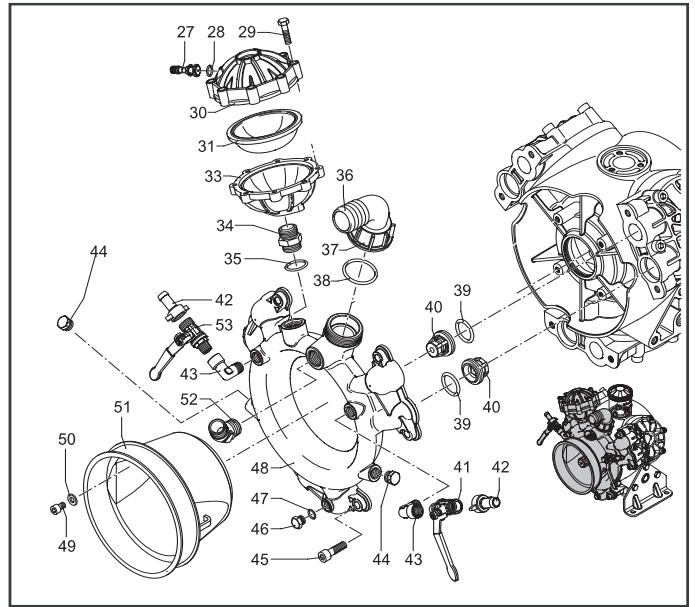
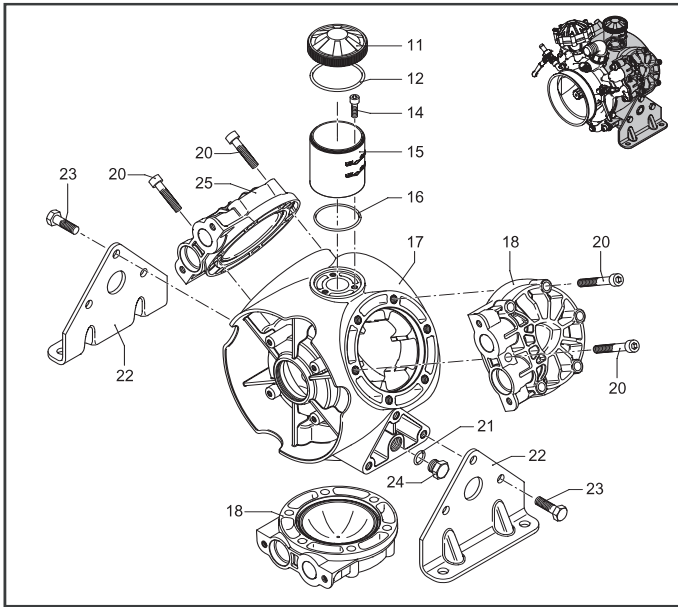

**NOTE:** From manifold side, heads on right side are marked with a "D" (#18) and heads on left side are marked with an "S" (#25).

## Parts List for Models 9910-DBA110 and 9910-DBA140

REF. NO.	PART NUMBER	DESCRIPTION	QTY. REQ'D
1	9910-2240100	Diaphragm pin	3
2	9910-580090	Retaining washer	3
3	9910-2240080	Diaphragm, Buna	3
4	9910-2240510	Sleeve DBA110	3
4	9910-2240520	Sleeve DBA140	3
5	9910-260230	Piston ring DBA110	3
5	9910-2240360	Piston ring DBA140	3
6	9910-2240060	Piston DBA110	3
6	9910-2240350	Piston DBA140	3
7	9910-260700	Piston pin DBA110	3
7	9910-540070	Piston pin DBA140	3
8	9910-160691	Pin ring	6
9	9910-2240090	Connecting rod	3
10	9910-2240110	Nut	3
11	9910-1800060	Black cap DBA110	1
11	9910-750050	Red cap DBA140	1
12	9910-1040060	O-Ring	1
14	9910-540290	M8x25 Bolt	3
15	9910-2240070	Oil sight glass	1
16	9910-2240270	O-Ring	1
17	9910-2240010	Pump body DBA110	1
17	9910-2240011	Pump body DBA140	1
18	9910-2240450	Right head (D)	2
20	9910-2240470	M12x70 Bolt	18
21	9910-180101	O-Ring	1
22	9910-2240190	Base	2
23	9910-540100	M12x40 Bolt	6
24	9910-820361	Plug	2
25	9910-2240451	Left head (S)	1
27	9910-180020	Air valve	1
28	9910-650542	Gasket	1
29	9910-621781	M8x40 Bolt	8
30	9910-629211	Upper air chamber	1
31	9910-550190	Air chamber diaphragm -Buna	1
33	9910-2240481	Lower air chamber	1
34	9910-2240490	Threaded Adaptor	8
35	9910-720030	O-Ring	1
36	9910-540550	Elbow 1-1/2"	1
37	9910-540540	Ring nut	1
38	9910-250310	O-Ring	1
39	9910-680070	O-Ring	6
40	9910-759051	Complete valve	6
41	9910-130491	Right valve	1
42	9910-110130	Hose barb 1/2"	2
43	9910-2240260	Valve elbow	2
44	2406-0023	Plug	2
45	9910-650330	M10x35 Bolt	6

REF. NO.	PART NUMBER	DESCRIPTION	QTY. REQ'D
46	9910-880581	Cap, brass	1
47	9910-820510	O-Ring	1
48	9910-2240461	Manifold	1
49	9910-850250	M8x12 Bolt	4
50	9910-390311	Washer	4
51	9910-1500470	Shield	1
52	9910-851650	Outlet elbow	1
53	9910-KIT2497	Left valve	1
60	9910-2240160	Snap ring	2
61	9910-2240150	Seal ring	2
62	9910-2240430	Bearing	2
63	9910-2240121	Con rod ring	2
64	9910-850320	Roller bearing	2
65	9910-2240173	Crankshaft	1
66	9910-2240290	O-ring	1
67	9910-2240020	Flange	1
68	9910-160670	M10x25 Bolt	6



**9910-KIT2444  
Diaphragm Kit**

REF. NO.	QTY.
3	3

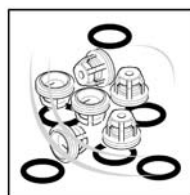

**9910-KIT2445  
Valve Kit**

REF. NO.	QTY.
39	6
40	6

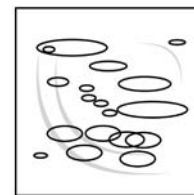

**9910-KIT2446  
O-Ring Kit**

REF. NO.	QTY.
12	1
16	1
21	2
35	1
38	1
39	6
47	1
66	1

REF. NO.	DESCRIPTION	Tightening Torque	
		In Lbs.	Nm
1	Dia. Pin	262.5	29.4
10	Nut	262.5	29.4
14	Bolt	87.5	9.8
20	Bolt	435.5	49.0
23	Bolt	435.5	49.0
24	Plug	171.4	19.6
27	Air valve	34.5	3.9
29	Bolt	171.4	19.6
44	Plug	171.4	19.6
45	Bolt	350.0	39.2
46	Brass cap	171.4	19.6
49	Bolt	87.5	9.8
68	Bolt	350.0	39.2

# Parts Illustrations for Models 9910-DBA160 and 9910-DBA200

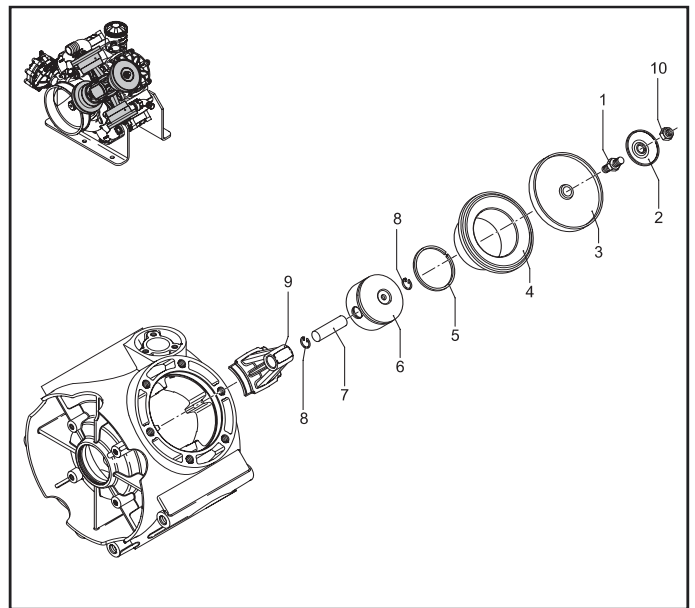
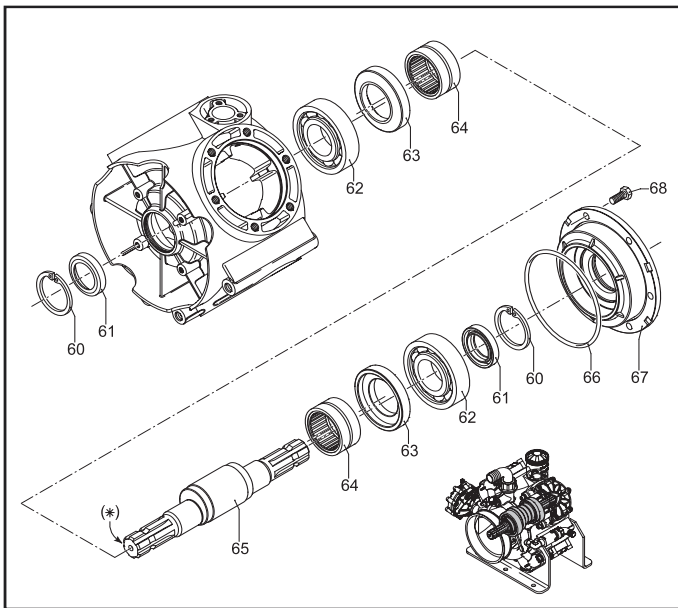
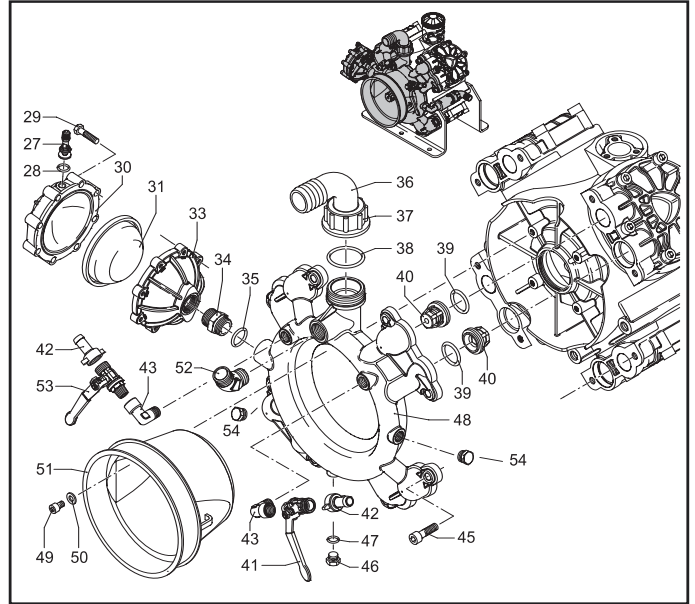
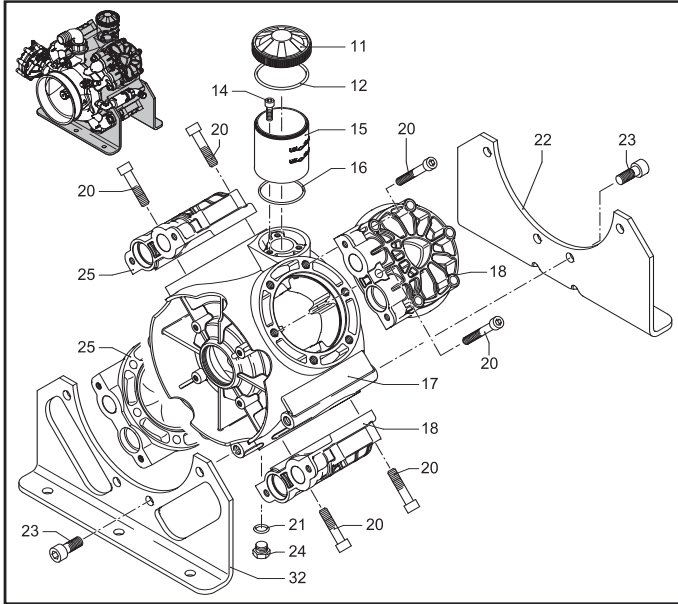

**NOTE:** From manifold side, heads on right side are marked with a "D" (#18) and heads on left side are marked with an "S" (#25).



## Parts List for Models 9910-DBA160 and 9910-DBA200

REF. NO.	PART NUMBER	DESCRIPTION	QTY. REQ'D
1	9910-2240100	Diaphragm pin	4
2	9910-580090	Retaining washer	4
3	9910-2240080	Diaphragm, Buna	4
4	9910-2240510	Sleeve DBA160	4
4	9910-2240520	Sleeve DBA200	4
5	9910-260230	Piston ring DBA160	4
5	9910-2240360	Piston ring DBA200	4
6	9910-2240060	Piston DBA160	4
6	9910-2240350	Piston DBA200	4
7	9910-260700	Piston pin DBA160	4
7	9910-540070	Piston pin DBA200	4
8	9910-160691	Pin ring	8
9	9910-2380050	Connecting rod	4
10	9910-2240110	Nut	4
11	9910-1800060	Black cap DBA160	1
11	9910-750050	Red cap DBA200	1
12	9910-1040060	O-Ring	1
14	9910-540290	M8x25 Bolt	3
15	9910-2240070	Oil sight glass	1
16	9910-2240270	O-Ring	1
17	9910-2380010	Pump body DBA160	1
17	9910-2380011	Pump body DBA200	1
18	9910-2240450	Right head (D)	2
20	9910-2240470	M12x70 Bolt	24
21	9910-180101	O-Ring	1
22	9910-2380040	Base	1
23	9910-2380060	M14x35 Bolt	8
24	9910-820361	Plug	1
25	9910-2240451	Left head (S)	2
27	9910-180020	Air valve	1
28	9910-650542	Gasket	1
29	9910-621781	M8x40 Bolt	8
30	9910-629211	Upper air chamber	1
31	9910-550190	Air chamber Diaphragm -Buna	1
32	9910-2380030	Base	1
33	9910-1520770	Lower air chamber	1
34	9910-1520740	Threaded adapter	8
35	9910-720030	O-Ring	1
36	9910-540550	Elbow 1-1/2"	1
37	9910-540540	Ring nut	1
38	9910-250310	O-Ring	8
39	9910-680070	O-Ring	8
40	9910-759051	Complete valve	8
41	9910-130491	Right valve	1

REF. NO.	PART NUMBER	DESCRIPTION	QTY. REQ'D
42	9910-110130	Hose barb 1/2"	2
43	9910-2240260	Valve elbow	2
45	9910-650330	M10x35 Bolt	8
46	9910-880581	Cap, brass	1
47	9910-820510	O-Ring	1
48	9910-2380071	Manifold	1
49	9910-850250	M8x12 Bolt	4
50	9910-390311	Washer	4
51	9910-1500470	Shield	1
52	9910-851650	Outlet elbow	1
53	9910-KIT2497	Left valve	1
54	2406-0023	Plug	2
60	9910-2240160	Snap ring	2
61	9910-2240150	Seal ring	2
62	9910-2240430	Bearing	2
63	9910-2240121	Con rod ring	2
64	9910-850320	Roller bearing	2
65	9910-2240173	Crankshaft	1
66	9910-2240290	O-ring	1
67	9910-2240020	Flange	1
68	9910-160670	M10x25 Bolt	6



**9910-KIT2456  
Diaphragm Kit**

REF. NO.	QTY.
3	4

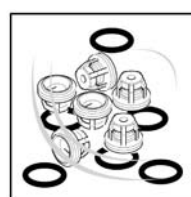

**9910-KIT2374  
Valve Kit**

REF. NO.	QTY.
39	8
40	8

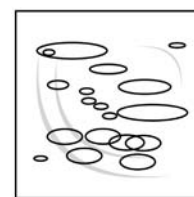

**9910-KIT2457  
O-Ring Kit**

REF. NO.	QTY.
12	1
16	1
21	1
35	1
38	1
39	8
47	1
66	1

REF. NO.	DESCRIPTION	Tightening Torque	
		In Lbs.	Nm
1	Dia. Pin	262.5	29.4
10	Nut	262.5	29.4
14	Bolt	87.5	9.8
19	Bolt	435.5	49.0
20	Bolt	435.5	49.0
23	Bolt	435.5	49.0
24	Plug	171.4	19.6
27	Air valve	34.5	3.9
29	Bolt	171.4	19.6
45	Bolt	350.0	39.2
46	Brass cap	171.4	19.6
49	Bolt	87.5	9.8
54	Plug	171.4	19.6
68	Bolt	350.0	39.2

# Performance Charts

## All 110 Series U.S. Units

PSI	350 RPM		450 RPM		500 RPM		550 RPM	
	GPM	HP	GPM	HP	GPM	HP	GPM	HP
0	18.5	0.5	23.4	0.9	25.8	1.2	28.5	1.5
435	18.0	5.1	22.7	6.7	25.3	7.5	27.8	8.2
580	17.9	6.7	22.6	8.7	25.2	9.7	27.6	10.6
725	17.7	8.3	22.6	10.7	25.1	11.8	27.3	12.9

## All 160 Series U.S. Units

PSI	350 RPM		450 RPM		500 RPM		550 RPM	
	GPM	HP	GPM	HP	GPM	HP	GPM	HP
0	26.9	0.9	33.7	1.7	36.6	2.2	39.7	2.7
435	26.1	7.1	32.9	9.1	36.5	10.1	38.9	11.1
580	26.0	9.2	32.5	11.8	36.2	13.2	38.6	14.2
725	25.8	11.3	32.5	14.4	35.6	15.9	38.3	17.6

## All 110 Series Metric Units

PSI	350 RPM		450 RPM		500 RPM		550 RPM	
	L/M	HP	L/M	HP	L/M	HP	L/M	HP
0	69.9	0.5	88.4	0.9	97.6	1.2	108.0	1.5
30	68.0	5.1	86.0	6.7	95.7	7.5	105.2	8.2
40	67.6	6.7	85.7	8.7	95.4	9.7	104.5	10.6
50	67.0	8.3	85.4	10.7	95.0	11.8	103.3	12.9

## All 160 Series Metric Units

PSI	350 RPM		450 RPM		500 RPM		550 RPM	
	L/M	HP	L/M	HP	L/M	HP	L/M	HP
0	101.9	0.9	127.4	1.7	138.7	2.2	150.1	2.7
30	98.8	7.1	124.6	9.1	138.0	10.1	147.1	11.1
40	98.4	9.2	123.2	11.8	137.2	13.2	146.3	14.2
50	97.7	11.3	122.9	14.4	134.7	15.9	145.0	17.6

## All 140 Series U.S. Units

PSI	350 RPM		450 RPM		500 RPM		550 RPM	
	GPM	HP	GPM	HP	GPM	HP	GPM	HP
0	25.0	0.9	31.6	1.7	34.6	2.2	37.6	2.7
435	23.9	7.0	30.5	9.0	34.1	10.0	36.9	11.0
580	23.6	9.0	30.3	11.6	33.8	13.2	36.5	14.1
725	23.0	10.9	29.4	14.1	32.9	15.7	35.6	17.1

## All 200 Series U.S. Units

PSI	350 RPM		450 RPM		500 RPM		550 RPM	
	GPM	HP	GPM	HP	GPM	HP	GPM	HP
0	37.0	1.3	43.8	2.5	46.8	3.2	49.8	3.9
435	36.2	9.0	43.0	11.4	46.5	12.6	49.0	13.9
580	36.1	11.5	42.6	14.7	46.4	16.7	48.7	17.7
725	35.9	13.9	42.6	17.8	45.7	19.8	48.4	21.8

## All 140 Series Metric Units

PSI	350 RPM		450 RPM		500 RPM		550 RPM	
	L/M	HP	L/M	HP	L/M	HP	L/M	HP
0	94.6	0.9	119.8	1.7	130.9	2.2	142.3	2.7
30	90.3	7.0	115.3	9.0	129.0	10.0	139.7	11.0
40	89.5	9.0	114.7	11.6	128.0	13.2	138.0	14.1
50	87.2	10.9	111.2	14.1	124.5	15.7	134.8	17.1

## All 200 Series Metric Units

PSI	350 RPM		450 RPM		500 RPM		550 RPM	
	L/M	HP	L/M	HP	L/M	HP	L/M	HP
0	140.1	1.3	165.7	2.5	177.0	3.2	188.4	3.9
30	137.2	9.0	162.8	11.4	176.2	12.6	185.6	13.9
40	136.7	11.5	161.4	14.7	175.5	16.7	184.5	17.7
50	135.9	13.9	161.3	17.8	173.1	19.8	183.3	21.8

NOTE: "HP" is electrical horsepower. Consult your gas engine supplier for engine horsepower required.

## Notes

## Limited Warranty on Hypro/SHURflo Agricultural Pumps & Accessories

Hypro/SHURflo (hereafter, "Hypro") agricultural products are warranted to be free of defects in material and workmanship under normal use for the time periods listed below, with proof of purchase.

- Pumps: one (1) year from the date of manufacture, or one (1) year of use. This limited warranty will not exceed two (2) years, in any event.
- Accessories: ninety (90) days of use.

This limited warranty will not apply to products that were improperly installed, misapplied, damaged, altered, or incompatible with fluids or components not manufactured by Hypro. All warranty considerations are governed by Hypro's written return policy.

Hypro's obligation under this limited warranty policy is limited to the repair or replacement of the product. All returns will be tested per Hypro's factory criteria. Products found not defective (under the terms of this limited warranty) are subject to charges paid by the returnee for the testing and packaging of "tested good" non-warranty returns.

No credit or labor allowances will be given for products returned as defective. Warranty replacement will be shipped on a freight allowed basis. Hypro reserves the right to choose the method of transportation.

This limited warranty is in lieu of all other warranties, expressed or implied, and no other person is authorized to give any other warranty or assume obligation or liability on Hypro's behalf. Hypro shall not be liable for any labor, damage or other expense, nor shall Hypro be liable for any indirect, incidental or consequential damages of any kind incurred by the reason of the use or sale of any defective product. This limited warranty covers agricultural products distributed within the United States of America. Other world market areas should consult with the actual distributor for any deviation from this document.

### Return Procedures

All products must be flushed of any chemical (ref. OSHA section 1910.1200 (d) (e) (f) (g) (h)) and hazardous chemicals must be labeled/tagged before being shipped\* to Hypro for service or warranty consideration. Hypro reserves the right to request a Material Safety Data Sheet from the returnee for any pump/product it deems necessary. Hypro reserves the right to "disposition as scrap" products returned which contain unknown fluids. Hypro reserves the right to charge the returnee for any and all costs incurred for chemical testing, and proper disposal of components containing unknown fluids. Hypro requests this in order to protect the environment and personnel from the hazards of handling unknown fluids.

Be prepared to give Hypro full details of the problem, including the model number, date of purchase, and from whom you purchased your product. Hypro may request additional information, and may require a sketch to illustrate the problem.

**Contact Hypro Service Department at 800-468-3428 to receive a Return Merchandise Authorization number (RMA#).** Returns are to be shipped with the RMA number clearly marked on the outside of the package. Hypro shall not be liable for freight damage incurred during shipping. Please package all returns carefully. All products returned for warranty work should be sent **shipping charges prepaid** to:

HYPRO  
Attention: Service Department  
375 Fifth Avenue NW  
New Brighton, MN 55112

For technical or application assistance, call the **Hypro Technical/Application number: 800-445-8360**, or send an email to: **technical@hypropumps.com**. To obtain service or warranty assistance, call the **Hypro Service and Warranty number: 800-468-3428**; or send a fax to the **Hypro Service and Warranty FAX: 651-766-6618**.

\*Carriers, including U.S.P.S., airlines, UPS, ground freight, etc., require specific identification of any hazardous material being shipped. Failure to do so may result in a substantial fine and/or prison term. Check with your shipping company for specific instructions.