

FILL-RITE®

**3200 Series DC High Flow Fuel Transfer
Pump**

Models FR3210B, FR3204



Table of Contents

Table of Contents	2
Thank You!	2
About This Manual	2
Safety Information	3
Installation	3
Electrical Wiring	7
Wiring Diagram	9
Operating Instructions	10
Pad Locking	10
Trouble Shooting	11
Servicing the Bypass Valve	12
Technical Information	13
Fluid Compatibility	13
Kits and Parts,	14
Accessories	15
Safety Approvals and Certifications	15
Motor Tag Information	15

Thank You!

Thank you for your purchase of the FR3200 series pump! Your Fill-Rite product comes with over 80 years of pump manufacturing experience behind it, providing you the value that comes with superior performance, user friendly design, long service life, and solid, simple engineering. Experience that gives you peace of mind.

Excellence at work. Excellence in life.

About This Manual

From initial concept and design through its final production, your Fill-Rite pump is built to give you years of trouble free use. To insure it provides that service, **it is critical that you read this entire manual prior to attempting to install or operate your new pump.** Become familiar with the terms and diagrams, and pay close attention to the highlighted areas with the following labels:



WARNING! Emphasizes an area in which personal injury or even death could result from failure to follow instructions properly. Mechanical damage may also occur.



IMPORTANT! These boxes contain information that illustrates a point that may save time or may be key to proper operation, or clarifies a step.



CAUTION! Failure to observe a “Caution” can cause damage to the equipment.

At Tuthill, your satisfaction with our products is paramount to us. If you have questions or need assistance with your product, please contact us at 1-800-634-2695 (M-F 8 AM–5 PM ET).

Safety Information



WARNING! Electrical wiring should be performed **ONLY** by a licensed electrician in compliance with local, state, and national electrical code NEC/ANSI/NFPA 70, NFPA 30, and NFPA 30A, as appropriate to the intended use of the pump. Threaded rigid conduit, sealed fittings, and conductor seal should be used where applicable. The pump must be properly grounded. Improper installation or use of this pump can result in serious bodily injury, or death!



WARNING! To insure safe and proper operation of your equipment, it is critical to read and adhere to all of the following safety warnings and precautions. Improper installation or use of this product can cause serious bodily injury or death!

- **NEVER** smoke near the pump, or use the pump near open flames when pumping a flammable liquid! Fire can result!
- A Fill-Rite Filter should be used on the pump outlet to insure no foreign material is transferred to the fuel tank.
- Threaded pipe joints and connections should be sealed with the appropriate sealant or sealant tape to minimize the possibility of leaks.
- Storage tanks should be securely anchored to prevent shifting or tipping when full or empty.
- To minimize static electricity build up, use only static wire conductive hose when pumping flammable fluids, and keep the fill nozzle in contact with the container being filled during the filling process.
- The pump motor is equipped with thermal overload protection; if overheated, the motor will shut off to prevent damage to the windings. If this happens, you must turn the power off to the pump to reset this safety feature, and turn the pump back on when cool to continue use.



WARNING! This product shall not be used to transfer fluids into any type of aircraft.



WARNING! This product is not suited for use with fluids intended for human consumption or fluids containing water.

Installation

The Fill-Rite 3200 Series pump is designed to be mounted on a skid tank using the threaded inlet flange supplied with the pump (see attached diagrams),

The FR3200 series pump features an integral bypass valve recirculate the fluid when the pump is operating with the nozzle closed.



WARNING! In Skid Tank applications, be sure the tank is properly secured so it cannot shift or move when the tank is empty or full.



CAUTION! Do not use additional check valves or foot valves unless they have a proper pressure relief valve built into them. Note that additional check valves will reduce rate of flow.



CAUTION! A pressure retaining fill cap can be used to reduce fuel loss through evaporation, but note that it will reduce the flow rate.



CAUTION! Threaded pipe joints and connections should be sealed with the appropriate sealant or sealant tape to prevent the possibility of leaks.



WARNING! The 3200 series pump is designed primarily for use with stationary tank applications. While the DC design makes it an excellent choice for mobile applications, anchoring the tank to which the pump is mounted is paramount to ensure no movement in transit. Failure to secure the tank to the vehicle can cause uncontrolled movement, resulting in damage, injury, and potential fire.

Typical Skid Tank Installation

The 3200 Series pump mounts to the bung of a skid tank by way of the inlet flange. The suction tube threads into the bottom of the inlet flange, and must be cut to a length that positions it at least 3" from the bottom of the tank. The skid tank should be equipped with a vent cap.

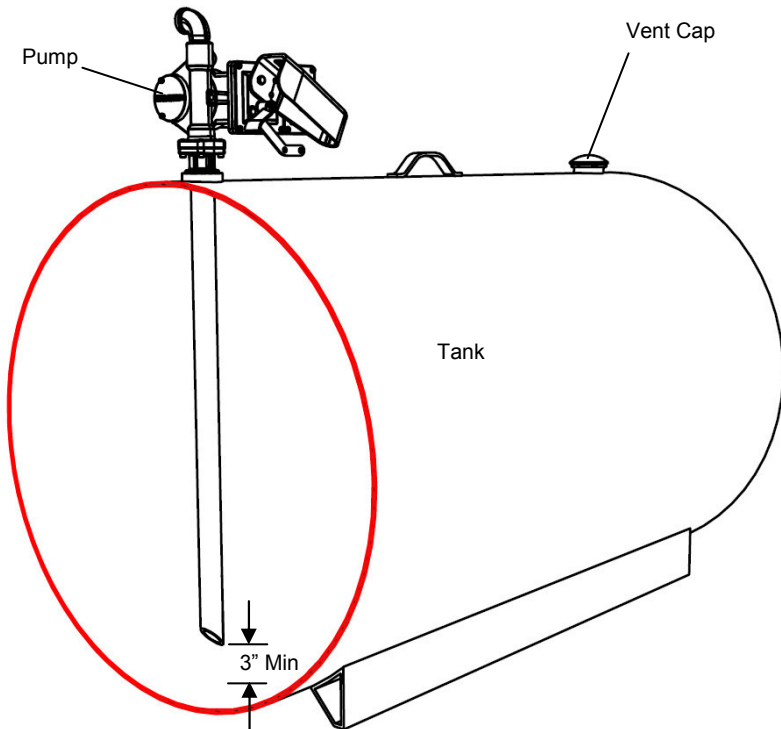

Typical Skid Tank Installation

Materials:

- 1-1/4" pipe cut to a length that will extend to within 3" of the bottom of the tank when screwed into the tank adapter with the tank adapter screwed into the tank flange (see **SKID TANK INSTALLATION** diagram).
- Threaded pipe joint sealant appropriate for application.

Installation Procedure:

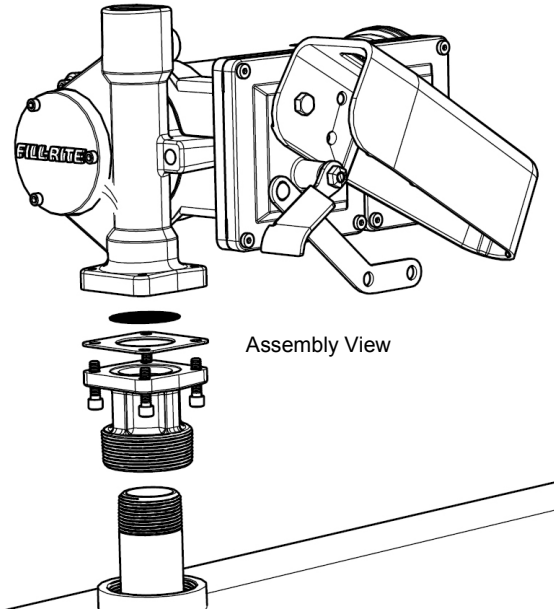

1. Thread the 1-1/4" pipe into the tank adapter. Seal threads liquid tight with appropriate sealant. (Figure 1)

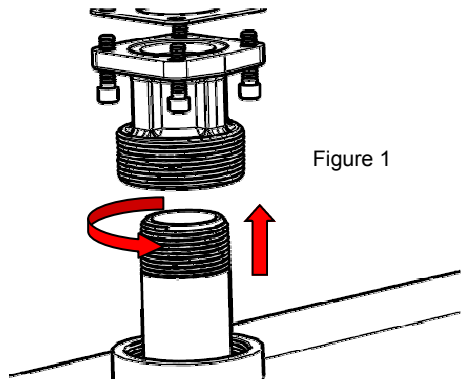

Typical Skid Tank Installation (cont'd)

2. Screw the inlet flange (with suction pipe) into the tank flange; seal threads liquid tight with appropriate thread sealant (Figure 2).

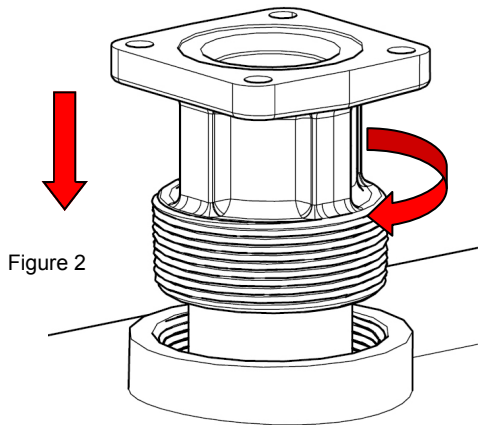

Figure 2

3. Mount the pump on the adapter; making sure the seal and screen are installed as shown. (Figure 3).

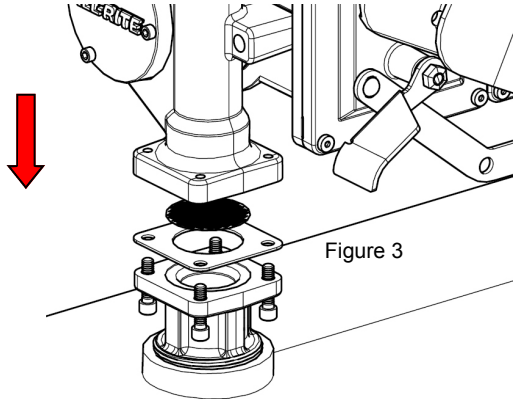

Figure 3

Electrical Wiring

Wiring Procedure



CAUTION! The FR3200 series pump is designed to operate on 12 VDC. Use the supplied battery cable to supply power to the pump from a 12 VDC battery. A 50 amp fuse should be installed on the battery cable (see wiring diagram page 9) to protect the wire in case of electrical short.



CAUTION! Voltage drop across a wire varies depending on the distance from the battery to the pump. If the distance is greater than 20', refer to the National Electrical Code (NEC) or local codes to ensure the wire is of the correct size being used for this application.

Instructions Before Proceeding With DC Wiring

The pump needs to be electrically bonded to supply tank or vehicle frame. To electrically bond pump, remove green bonding screw located next to junction box cover. Insert this screw through eyelet of furnished green bonding wire assembly and refasten it securely to the pump. The other end of the wire is to be stripped of insulation and the bare wire securely bonded to the vehicle / trailer frame or skid tank.



WARNING! Do not connect the positive or negative power to the green screw or wire as this could cause a fire.

Wiring Instructions (see Figure 4, Page 8)

1. Remove pump's electrical junction box cover and straighten the 2 wires to make the stripped wire ends accessible outside of the junction box.
2. Screw furnished cable connector into NPT conduit opening in pump junction box.
3. Strip 6 inches of the outer covering from one end of the furnished electrical cable being careful not to damage the black and red wire insulation.
4. Loosen cable connector nut and pass the stripped end of the furnished cable through the cable connector. Tighten the cable connector nut.
5. Strip ½ inch of the installation from the ends of the red and black cable wires. Using the furnished wire nuts, connect these wires to the pump wires matching the colors. Be sure no bare wire is exposed.
6. Fold wires into junction box and replace cover making sure the gasket is in place. Make sure all screws are seated so there is no space between the cover and the junction box.

Wiring To A Vehicle Electrical System (see Wiring Diagram, Page 9)

1. Pass the electrical wires to the source of the vehicle power system, supporting the wires as necessary and protecting it from sharp edges, heat, and anything that could damage the wires.
2. To determine if the vehicle electrical system is **negative (-)** or **positive (+)** ground, check the battery marking of the terminal that is wired to the vehicle frame or motor block. The red wire from the pump will connect to positive battery post and the black wire from the pump will connect to negative battery post.
3. Attach one end of the fuse holder to the end of the ungrounded pump wire. Make a solid electrical connection with the other end of the fuse holder to the ungrounded side of the battery. Make a solid electrical connection to the grounded side of the battery with the remaining pump wire. The battery terminal or the end of the battery cable is recommended.
4. Check all connections to make sure they are connected per instructions and all electrical codes. Install the 50 amp fuse in the fuse holder. The installation is now complete.



WARNING! Do not attempt to power the pump from vehicle wiring smaller than 10 gage such as the cigarette lighter wire because these thin wires could overheat and cause a fire.

DC Wiring (cont'd)**For Skid Mounted Tanks**

1. Pass the electrical wires to the power source, supporting the wires as necessary and protecting them from sharp edges, heat and anything that could damage the wires.
2. Attach one end of the fuse holder to the **red** pump wire. Make a solid electrical connection to the **positive** terminal of the power source with the other end of the fuse holder. Make a solid connection with the **black** pump wire to the **negative** terminal of the power source.
3. Check all connections to make sure they are connected per instructions and all electrical codes. Install the 50 amp fuse in the fuse holder. The installation is now complete.

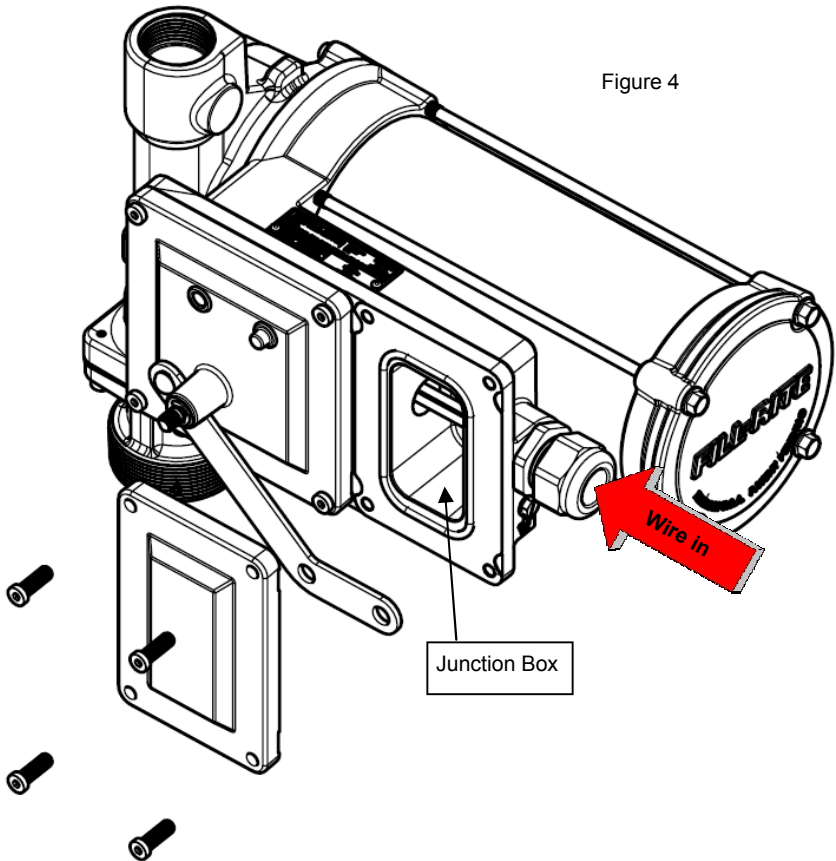

Wiring Diagram

POSITIVE GROUND SYSTEM

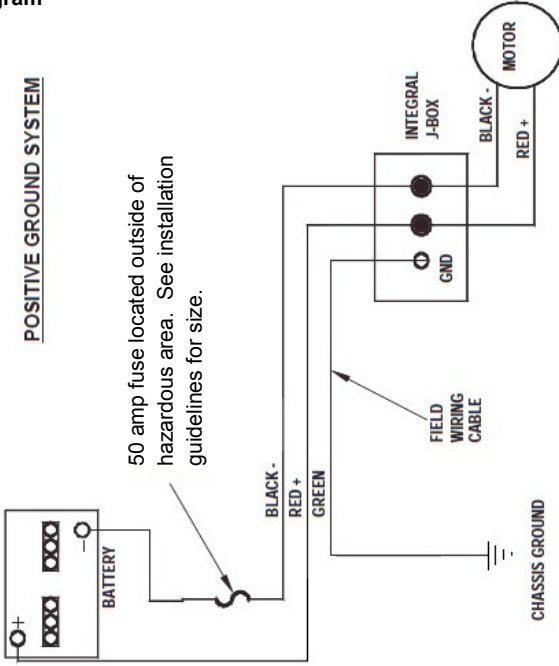

Illust. 2

NEGATIVE GROUND SYSTEM

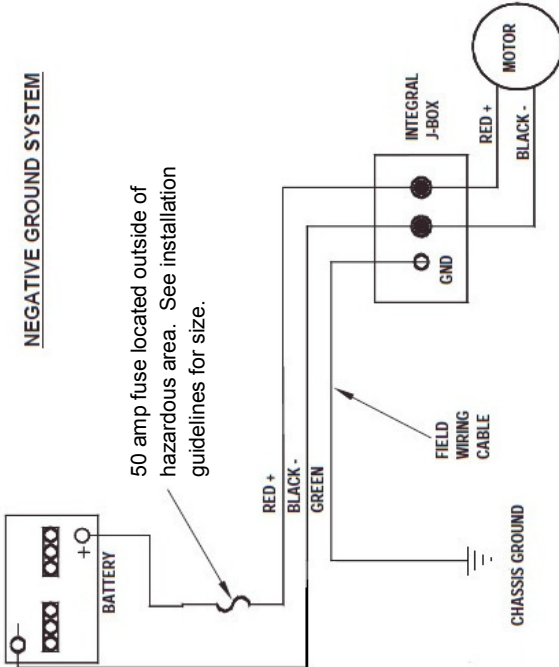

Illust. 1

Operating Instructions



CAUTION! Always keep the nozzle in contact with the container being filled during the filling process to minimize the possibility of static electricity build up.

1. If so equipped, reset Meter to "0" (do not reset while in use as this can cause damage to the meter).
2. Remove dispensing nozzle from nozzle boot.
3. Move the switch lever to the "ON" position to power the pump (figure 5).
4. Insert the dispensing nozzle into the container to be filled.
5. Operate the nozzle to dispense fluid; release nozzle when the desired amount of fluid has been dispensed.

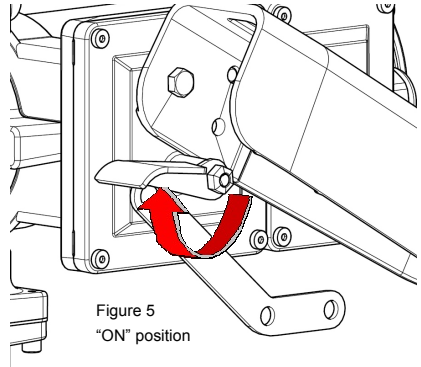

Figure 5
"ON" position

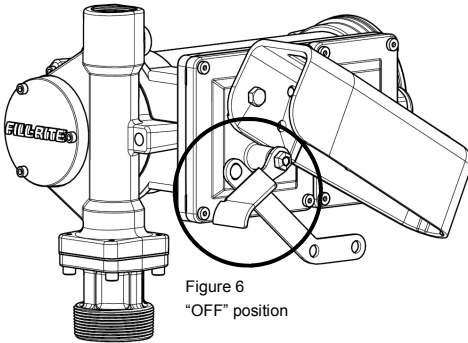

Figure 6
"OFF" position

6. Move switch lever to the "OFF" position (Figure 6) to turn off the pump.
7. Remove the dispensing nozzle from the container being filled and store it in the nozzle boot.

Pad Locking

Your Fill-Rite pump nozzle can be pad locked to the pump for added security. With the pump turned off, and the nozzle in the stored position, a pad lock can be inserted through the locking link and the nozzle handle opening. This configuration prevents the nozzle from being removed from the nozzle cover.

The locking link is located on the nozzle side of the pump, and can be pivoted into position to work with a variety of nozzles (Figure 7).

Use the appropriate position and hole to lock your nozzle securely to your FR3200 series pump.

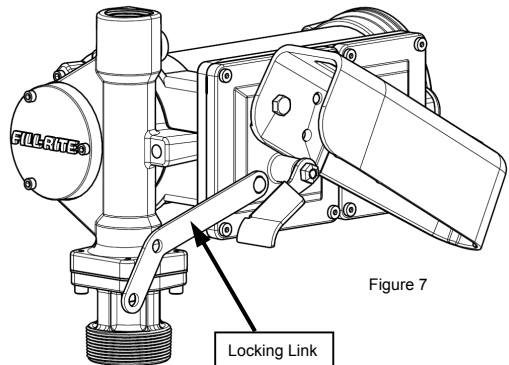

Figure 7

Trouble Shooting

The following Trouble Shooting guide is provided to offer basic diagnostic assistance in the event you encounter abnormal service from your Tuthill product.

If you have questions regarding installing, operating, or servicing your product, please feel free to contact our Customer Service Department at 1-800-634-2695 (M-F 8 AM-5 PM ET). You can also reach us on the World Wide Web at "www.fillrite.com".



WARNING! DO NOT open or attempt to repair the motor on your Tuthill pump. Return it to the place of purchase for service. Opening the motor case can compromise the integrity of the Explosion Proof construction and will void any existing warranty and certification (UL listing).



WARNING! Be certain all power to the pump is disconnected prior to performing any service or maintenance.

Symptom	Cause	Cure
Pump won't prime.	1. Suction line problem.	Check for leaks in suction line
	2. Bypass valve open.	Remove and inspect valve; must move freely & be free of debris.
	3. Vanes sticking.	Check vanes and slots for nicks, burrs and wear.*
	5. Excessive rotor or vane wear.	Inspect rotor & vanes for excessive wear or damage; replace if necessary.*
	6. Outlet blocked.	Check pump outlet, hose, nozzle & filter for blockage.
	7. Vapor Lock	Reduce vertical and horizontal distance from pump to liquid; remove automatic nozzle.
	Low capacity.	1. Excessive dirt in screen.
2. Suction line problem.		Check suction line for leaks or restrictions; it may be too small, too long or not airtight.
3. Bypass valve sticking.		Remove and inspect valve; must move freely & be free of debris.
4. Vanes sticking.		Check vanes and slots for wear.
5. Excessive rotor or vane wear.		Inspect rotor & vanes for excessive wear or damage; replace if necessary.*
6. Hose or nozzle damage.		Replace hose or nozzle.
7. Plugged filter.		Replace filter.
8. Low fluid level.		Fill tank.
Pump runs slowly.	1. Incorrect voltage.	Check incoming line voltage while pump is running.
	2. Vanes sticking.	Inspect vanes and slots for nicks, burrs and wear.*
	3. Wiring problem.	Check for loose connections.
	4. Motor problem.	Return to place of purchase.

See page 12 for explanation of **Bold text** and * items.

Trouble Shooting (cont'd)

Motor stalls / Fuse blows or circuit breaker trips repeatedly.	1. Bypass valve sticking.	Remove and inspect valve; must move freely & be free of debris.
	2. Low voltage.	Check incoming line voltage while pump is running.
	3. Excessive rotor or vane wear.	Check rotor & vanes for excessive wear or damage.*
	4. Debris in pump cavity.	Clean debris from pump cavity.
Motor overheats.	1. Pumping high viscosity fluids.	These fluids can only be pumped for short periods of time (less than 30 minutes duty cycle).
	2. Clogged screen.	Remove and clean screen.
	3. Restricted suction pipe.	Remove and clean pipe.
	4. Motor failure.	Return to place of purchase.
	5. Pump rotor lock-up.	Clean and check pump rotor and vanes.
Motor Inoperative.	1.No power	Check incoming power.
	2. Switch failure.	Replace switch (KIT320SW).
	3. Motor failure.	Return to place of purchase.
	4. Thermal protector failure.	Return to place of purchase.
	5. Incorrect/loose wiring.	Check wiring.
Fluid leakage.	1. Bad o-ring gasket.	Check all o-ring gaskets.
	2. Dirty shaft seal.	Clean seal & seal cavity.
	3. Bad shaft seal.	Replace seal.
	4. Incompatible fluid.	Refer wetted parts list to fluid manufacturer.
	5. Loose fasteners.	Tighten fasteners.
Pump hums but will not operate.	1. Motor failure.	Return to place of purchase.
	2. Broken key.	Remove all debris & replace key.

Bold text indicates repairs that are not serviceable by the owner; pump must be returned to the point of purchase for repairs.

* Repairs marked with an asterisk (*) will require Repair Kit KIT320RG. This kit includes a replacement rotor and new vanes, as well as a number of other important seals and components to complete the repair. Details of this kit are on page 14.

Servicing the Bypass Valve



WARNING! Disconnect electrical power and relieve any pressure in the lines prior to servicing this pump! Failure to do so can result in damage to the equipment and personal injury or death!



IMPORTANT! Removal of the bypass valve in the FR3200 series pump requires special attention; please adhere to the replacement procedure in the kit instructions to minimize the possibility of damaging the pump housing during the removal and installation process. Kit instructions are available at www.fillrite.com

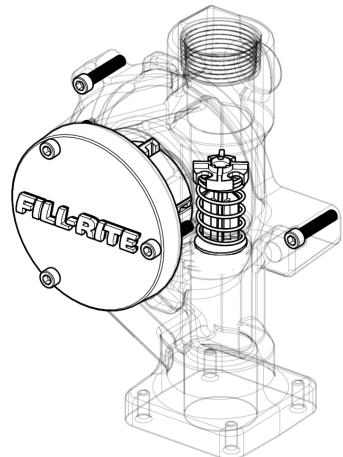

Technical Information

Motor	
Power -AC 115, 230, 115/230	N/A
HZ 50, 60, 50/60	N/A
Power - DC 12, 24, 12/24	12 VOLT
HP (horsepower) rating	1/2 HP
Power cord length	20'
Power cord gauge	10 AWG
Power cord DC battery connectors	N/A
Amps (FLA)	45 A
RPM	3600
Duty cycle	30 min.
Thermal protection switch	Yes
Circuit protection fuse	Yes (Circuit Breaker)
Certification	UL/cUL Motor
Pump	
Type- rotary, diaphragm, gear, vane	Rotary Vane
GPM in supplied configuration	Up to 28
GPM open flow - no hose or nozzle	Up to 28.6
By-pass pressure rating (psi) - Max	22 psi
Dry vac (in Hg)	12
Head- Max	50.8
Anti-siphon valve	None
Inlet - Size / Thread	1-1/4"
Outlet – Size / Thread	1" NPT
Mount	2" Bung (NPT)
Materials of construction -pump housing	Cast Iron
Materials of construction- wetted material	BUNA-N
Rotor materials of construction	Powdered Iron
Rotor vane material of construction	Acetal
Compatible fluids	Diesel, gasoline, BioDiesel up to B20, E15, Kerosene
Strainer Mesh Size	20 x 20
Warranty (yr)	2 Years

Kits and Parts

Kit Number	Description	Parts
KIT320RK	Overhaul Kit	Rotor, rotor cover, vanes, O-ring seal, shaft seal kit, bypass valve, inlet seal & screen, rotor key, attaching hardware
KIT320RG	Rotor & Vane Kit	Rotor cover, rotor, vanes, rotor key, O-ring seal, attaching hardware
KIT320SL	Seal Kit	O-ring, shaft seals, retainer clip
KIT320BV	By-Pass Service Kit	Inlet gasket, screen, bypass valve, valve spring, valve retainer
KIT120NB	Nozzle Boot Kit	Nozzle boot, attaching hardware
KIT320SK	External Seal Kit	O-ring seal, inlet gasket, electrical cover seals
KIT320BG	Inlet Flange Kit	Inlet flange (bung), attaching hardware, inlet seal, screen
KIT320SW	Switch / Breaker Kit	Breaker / switch assembly, switch mounting bracket, attaching hardware, cover gasket
KIT320MK	Motor Kit	Complete motor assembly

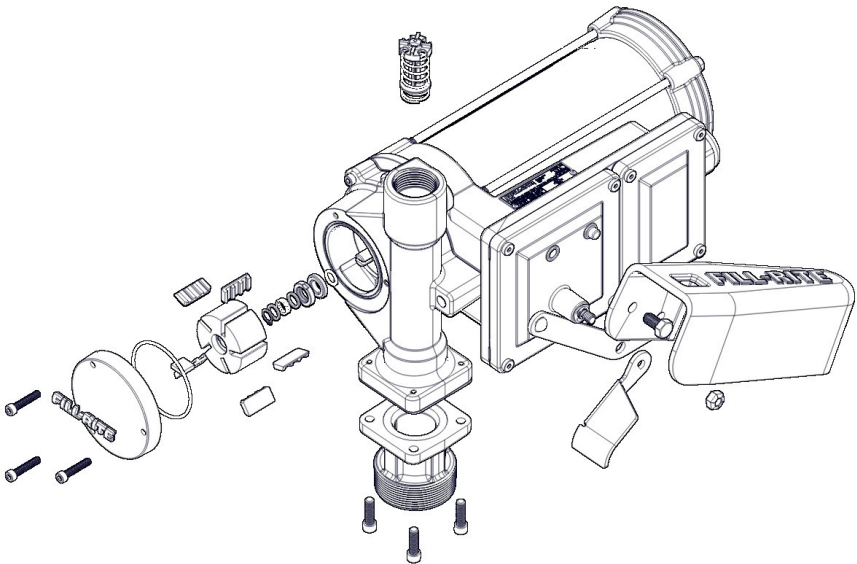

Accessories

Accessory	Description
N100DAU13	1" Ultra High Flow Manual Nozzle
FRHMN100S	1" Manual Nozzle
900D	900D Digital Meter
NEW	900DP Digital Meter with Pulsar (Coming Soon)
FRH10020	20' x 1" Static Discharge Hose
FRH10012	12' x 1" Static Discharge Hose
NEW	1" multi plane swivel (Coming Soon)

Safety Testing Approvals

The **Fill-Rite** line of pumps have been safety tested for compliance to the standards set forth by Underwriters Laboratories.



Motor Tag Information

The Motor Tag on your FR3200 series pump contains important technical and performance information. Be certain this label remains affixed to the pump at all times.

		Fort Wayne Indiana USA	MADE IN U.S.A. LB000659-000
SA000763-000 EXPLOSION-PROOF MOTOR			
12 VDC	45 AMPS	 LISTED ELECTRIC MOTOR FOR HAZARDOUS LOCATION	CLASS 1 GROUP D
1/2 HP	3600 RPM		
30 MIN. DUTY	-40°C TO 40°C AMB.		
INSUL. CLASS H	OPER. TEMP. CODE T2D		
THERMALLY PROTECTED		NO. F <input type="text"/>	
WW / YY			

↑
Date stamp location

Visit us on the web at:

www.fillrite.com

Learn more about Tuthill Corporation and our family of high quality, value minded products at:

www.tuthill.com

FILL-RITE®

8825 Aviation Drive
Ft. Wayne, IN 46809
1-800-634-2695
