

# CONTINENTAL

**NH<sub>3</sub> PRODUCTS CO., INC.**

The Quality Line

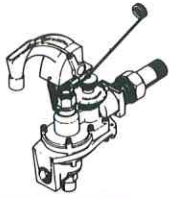

## C-4100 SERIES *MeterMatic*

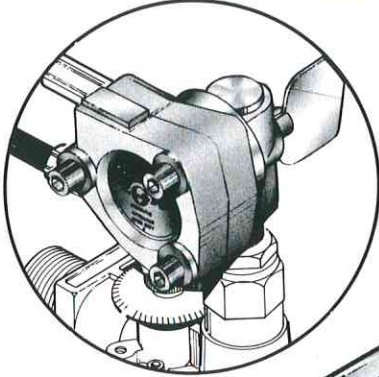

Rotary Actuator  
R-6572

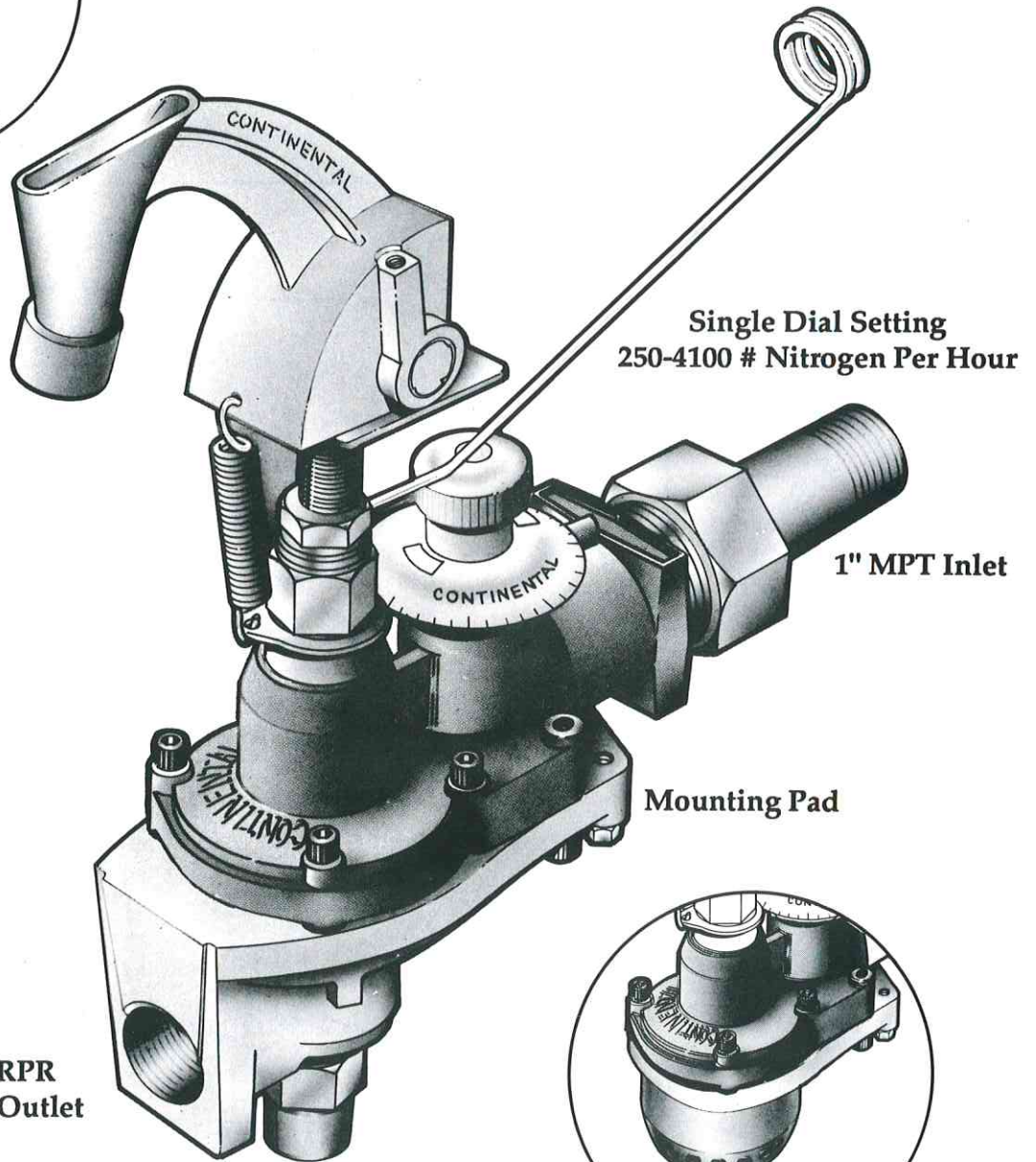

Single Dial Setting  
250-4100 # Nitrogen Per Hour

1" MPT Inlet

Mounting Pad

C-4103 RPR  
Single 1" Outlet

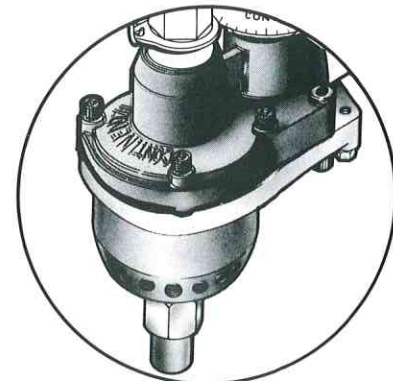

C-4100 RPR  
Multiple Outlet (14)



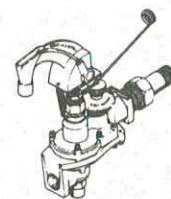

### C-4100 Series SETTING INSTRUCTIONS

Simplicity in setting the CONTINENTAL METER MATIC is one of its outstanding features and is based on the following known values:

1. Desired amount of 'N' to be applied in lbs. per acre.
2. Swath Width. (in feet).
3. Tractor Speed. (MPH)

#### HOW TO SET METER MATIC FOR APPLICATION RATES SHOWN ON DIAL FORMULA FOR SETTING C-2500, C-4100, AND B-9500

If appropriate charts are not available use the formula Lbs. Nitrogen X Swath Feet X MPH X .1212 = Lbs. Nitrogen in one hour.

Example:	Lbs. Nitrogen per Acre	100
	Swath width in feet	30
	Tractor speed	5

$$\text{Lbs. Nitrogen} \times \text{swath feet} \times \text{MPH} \times .1212 = \text{Nitrogen applied in one hour}$$

$$100 \times 30 \times 5 \times .1212 = 1818 \text{ Lbs. Nitrogen per hour.}$$

This will be the dial setting at 100# pressure in a normal fitting arrangement. (12 feet of 1" hose X hose valve X 1-1/4" QDC X 3' of 1" hose).

This setting number is then multiplied by the tank pressure multiplier on the dial (if not 100 lbs. tank pressure) in order to get the actual dial setting.

If using charts, find setting number then multiply the setting number by the tank pressure multiplier = dial setting.

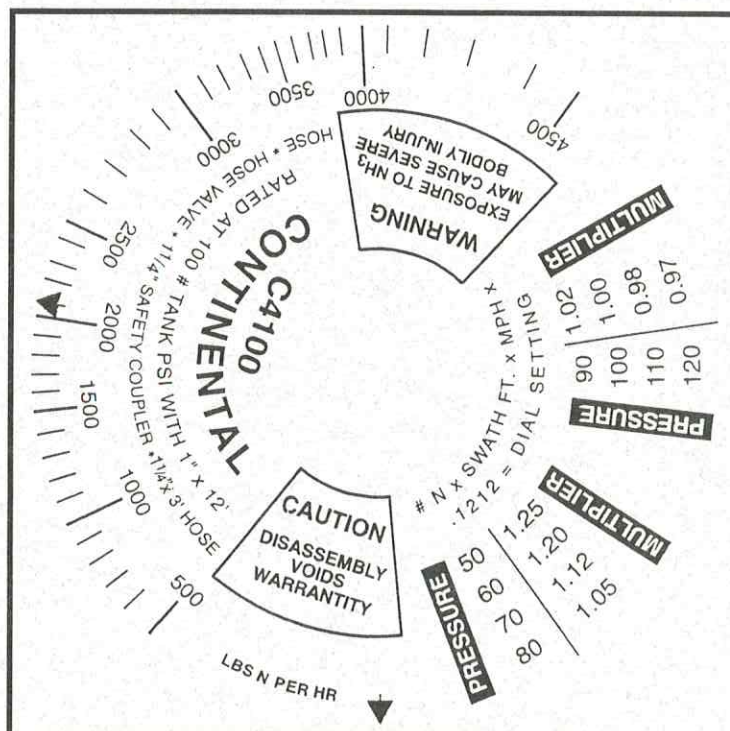



## CARE & MAINTENANCE: *IMPORTANT*

The METER MATIC is a precision metering device and it will perform more accurately and with very little maintenance if only a few simple precautions are followed.

1. The unit should be protected from the elements as much as possible when not in service.
2. At close of applying season, or if out of service for extended period of time, disconnect meter and clean out sediment or foreign matter from meter-barrel, manifold, and hose barbs.

**CAUTION: BE CERTAIN TANK VALVE IS SECURELY CLOSED AND ALL AMMONIA HAS BEEN EVACUATED FROM METER MATIC BEFORE DISCONNECTING.**

3. Apply several drops of light lubricating oil on meter barrel, both below the dial and through the inlet opening.
4. Rotate the dial several times to allow oil to penetrate seal and barrel housing.
5. Store inside during off-season if at all possible.

## TROUBLE CHECK

### A. CAUSES FOR INACCURACY

1. Dial Setting - Recheck setting instructions.
2. Liquid Withdrawal - Check supply tank for adequate supply of liquid.
3. Excessive Frosting - Frosting of lower body is normal, frosting of upper indicates possible inaccuracy.
  - (a) Frost formed on upper body including inlet union and strainer indicates restriction in the withdrawal valve or in hose and/or couplings.
  - (b) Frost formed on upper body excluding union nut indicates
    - (1) Clogged strainer screen - Remove and clean out.
    - (2) Ruptured diaphragm - See instructions "B" - DISASSEMBLY
    - (3) Restriction of meter-barrel by-pass canal. = See "B" - DISASSEMBLY

### B. LEAKS

1. If leak develops at diaphragm between upper and lower bodies it can usually be stopped by tightening cap screws (01-2520-100 & (01-2520-125). If this fails, replace diaphragm. See "B" DISASSEMBLY
2. Leak thru discharge hoses when Quick Shut-off is closed.

Note: The Quick Shut-Off is designed to function as a safety release in the event the tank valve left open and pressure allowed to build up in the METER MATIC. Tank valve should **always be closed when meter not in use.**

  - (a) Foreign matter lodged or imbedded in seat (A-01-36).
  - (b) Damaged or worn out seat (A-01-36).
  - (c) Check stem shut-off adjustment.
    - (1) To correct (a), (b), or (c) above See instructions "A" - DISASSEMBLY and instruction "B" ASSEMBLY.
3. Leak thru and around Cam Housing Assembly (01-22). Check and adjust stem packing. See instructions "C" DISASSEMBLY.
4. Leak under dial. See instructions 2 & 3 - CARE & MAINTENANCE.
  - (a) Replace cap seal. See instructions "D" - DISASSEMBLY.



## DISASSEMBLY

For field repair and maintenance of the METER MATIC the following instructions and procedure is suggested:

**CAUTION: BE SURE THAT TANK VALVE IS SECURELY CLOSED AND ALL AMMONIA HAS BEEN EVACUATED FROM METER MATIC BEFORE ATTEMPTING DISASSEMBLY.**

### A. REPLACE QUICK-SHUT-OFF SEAT

1. Remove plug (41-26) and spring (65-91X)
2. Remove seat assembly (A-65-37) and replace with new part.

### B. REPLACE DIAPHRAGM

1. Remove six cap screws (01-2520-100; 01-2520-125) and the lower body can then be removed.
2. Remove Quick Shut-off Assembly by removing bonnet (A-41-24).
3. Holding screw driver in slot of stem (65-34) back-off throttle seat (41-35).
4. Upper diaphragm plate (01-80) and diaphragm (41-72) can then be removed.
5. Replace old diaphragm with new one and proceed with re-assembly.

### C. ADJUST OR REPLACE QUICK SHUT-OFF STEM PACKING

1. Loosen lower lock nut (01-14) and remove cam assembly. Turn counter clockwise.
2. Remove Quick Shut-off seat. Instruction "A" - DISASSEMBLY
3. To tighten packing - Depress stem until screw driver engages slot in packing follower (01-31). Turn clockwise to tighten. Do not over-tighten.
4. To remove packing - Turn follower in counter-clockwise direction.
5. Replace packing if necessary and re-assemble.
6. Adjust stem - See instruction "B" - ASSEMBLE

### D. REPLACE CAP SEAL

1. Apply penetrating oil or solvent to meter-barrel, both below the dial and thru screen opening. Allow sufficient time to penetrate to seal, barrel, and body housing.
2. Loosen set screw in dial knob. (01-832-25)
3. Drive out lock pin. (01-92BF) Support knob to prevent bending stem.
4. Remove burrs from barrel stem caused by lock pin and set screw. Failure to do so will damage new seal.
5. Press meter barrel out of housing. **DO NOT DRIVE OUT.** If meter barrel is badly corroded, return upper body assembly to factory for overhaul.
6. Remove old cap seal and thoroughly clean both barrel and housing. It may be necessary to remove corrosion with steel wool.
7. Insert new cap seal (65-71BF) into recess in body. Be careful not to twist seal when installing.
8. Insert meter barrel back into body and install dial assembly. Be sure that dial and orifice in meter barrel is in the same relation as when removed.



## ASSEMBLY

Before proceeding with assembly, all parts should be thoroughly cleaned and free of scale, grit, etc. All parts with the exception of diaphragm should be lightly oiled before re-assembly.

### A. QUICK SHUT-OFF

1. Insert lower stem (65-34) into bonnet (41-24)

**NOTE: Care should be exercised in this operation in order not to damage seal (65-71BF).**

2. Install spring (65-90) over stem (65-34) and place into body. Be sure that spring fits evenly into recess in body casting.
3. Assemble new diaphragm (41-72) between upper (01-80) and lower (65-81) plates and hand-tighten to stem (65-34) by inserting throttle set (41-35). See instruction "B" - REPLACE DIAPHRAGM.
4. Back-off adjusting screw and ratchet assembly and hold stem (65-34) with screw driver in slot. Tighten seat (41-35) securely with wrench.
5. Re-insert bonnet assembly and tighten securely into casting body.
6. Install lower body by reversing operation "B" - 2 IN DISASSEMBLY. Care should be exercised so that diaphragm fits smoothly and is free of wrinkles. The six cap screws are then tightened equally in rotation.
7. Assemble shut-off seat (A65-36), the spring (65-91X), and plug (41-26).

### B. ADJUST QUICK SHUT-OFF

1. Loosen lower lock nut (01-14) and raise or lower cam housing adjusting screw (65-11B) until cam rod (65-13) and stem (41-15) contact each other. Turn adjusting screw counter clockwise one half turn. Lock down with lower lock nut. The cam, stems, and seat linkage are now in correct adjustment.
2. Loosen upper lock nut and turn cam housing and rope pull casting to desired position. Lock down tight.



## NOTICE

1. THE R9590 AND R6572 HYDRAULIC ACTUATORS DO NOT USE A "POSITIVE SEAL". THEY WILL ALLOW PRESSURE TO BLEED BACK TO THE RETURN LINE.
2. CONTINENTAL NH3 RECOMMENDS THAT THESE HYDRAULIC ACTUATORS HAVE A SEPARATE AND ISOLATED SPOOL VALVE CONTROL.
3. IF THESE ACTUATORS MUST BE CONNECTED TO THE SAME SPOOL VALVE AS THE TOOL BAR CYLINDER (S), THEN A PILOT OPERATED BACK CHECK CONNECTED TO THE TOOL BAR CYLINDER (S) MAY PREVENT "BLEED BACK".
4. THESE ACTUATORS REQUIRE 1/4" HYDRAULIC HOSES AND FITTINGS.

## WARNING

1. OVERTIGHTENING ORIFICED ADAPTERS MAY CAUSE CASTING TO CRACK. ALWAYS USE BACK-UP WRENCH ON ADAPTER WHEN CONNECTING HYDRAULIC LINES.
2. IN THE EVENT OF TRACTOR POWER FAILURE WHERE IT BECOMES NECESSARY TO SHUT OFF HYDRAULIC ACTUATOR, SEVER OR DISCONNECT BOTH HYDRAULIC LINES AT THE ACTUATOR BODY AND MANUALLY TURN FLAG ACTUATOR TO OFF POSITION.
3. TO AVOID CROSS THREADING OR GALLING, USE LEAD BASE ANTI-SEIZE THREAD SEALANT (AVAILABLE AT CONTINENTAL NH3).

# CONTINENTAL PRODUCTS CO., INC.

C-2500 **RED**

C-4100 **RED & BLUE**

B-9500 **RED, BLUE & WHITE**

LBS. NITROGEN PER ACRE

(INCH) 240 SWATH 20 FT.

SPEED @ 100 LBS. TANK PRESSURE - USE DIAL MULTIPLIER FOR PRESSURES ABOVE AND BELOW 100 LBS.  
MPH 40 50 60 75 80 100 120 140 150 160 180 200 220 240 250 260 280

3.0	291	364	436	545	582	727	873	1018	1091	1164	1309	1454	1600	1745	1818	1891	2036
3.5	339	424	509	636	679	848	1018	1168	1273	1357	1527	1697	1866	2036	2121	2206	2376
4.0	388	485	582	727	776	970	1164	1357	1454	1551	1745	1939	2133	2327	2424	2521	2715
4.5	436	545	654	818	873	1091	1309	1527	1636	1745	1963	2182	2400	2618	2727	2836	3054
5.0	485	606	727	909	970	1212	1454	1697	1818	1939	2182	2424	2666	2909	3030	3151	3394
5.5	533	667	800	1000	1067	1333	1600	1866	2000	2133	2400	2666	2933	3200	3333	3466	3733
6.0	582	727	873	1091	1164	1454	1745	2036	2182	2327	2618	2909	3200	3491	3636	3781	4072
6.5	630	788	945	1182	1260	1576	1891	2206	2363	2521	2836	3151	3466	3781	3939	4097	4412
7.0	679	848	1018	1273	1357	1697	2036	2376	2545	2715	3054	3394	3733	4072	4242	4412	4751
7.5	727	909	1091	1364	1454	1818	2182	2545	2727	2909	3272	3636	4000	4363	4545	4727	5090
8.0	776	970	1164	1454	1551	1939	2327	2715	2909	3103	3491	3878	4266	4654	4848	5042	5430

LBS. NITROGEN PER ACRE

(INCH) 252 SWATH 21 FT.

SPEED @ 100 LBS. TANK PRESSURE - USE DIAL MULTIPLIER FOR PRESSURES ABOVE AND BELOW 100 LBS.  
MPH 40 50 60 75 80 100 120 140 150 160 180 200 220 240 250 260 280

3.0	305	382	458	573	611	764	916	1069	1145	1222	1374	1527	1680	1833	1909	1985	2138
3.5	356	445	534	668	713	891	1069	1247	1336	1425	1603	1782	1960	2138	2227	2316	2494
4.0	407	509	611	764	814	1018	1222	1425	1527	1629	1833	2036	2240	2443	2545	2647	2851
4.5	458	573	687	859	916	1145	1374	1603	1718	1833	2062	2291	2520	2749	2863	2978	3207
5.0	509	636	764	954	1018	1273	1527	1782	1909	2036	2291	2545	2800	3054	3182	3309	3563
5.5	560	700	840	1050	1120	1400	1680	1960	2100	2240	2520	2800	3080	3360	3500	3640	3920
6.0	611	764	916	1145	1222	1527	1833	2138	2291	2443	2749	3054	3360	3665	3818	3971	4276
6.5	662	827	993	1241	1324	1654	1985	2316	2482	2647	2978	3309	3640	3971	4136	4301	4632
7.0	713	891	1069	1336	1425	1782	2138	2494	2672	2851	3207	3563	3920	4276	4454	4632	4989
7.5	764	954	1145	1432	1527	1909	2291	2672	2863	3054	3436	3818	4200	4581	4772	4963	5345
8.0	814	1018	1222	1527	1629	2036	2443	2851	3054	3258	3665	4072	4480	4887	5090	5294	5701

ALL METERS ARE CALIBRATED WITH CONTINENTAL FITTINGS AT 100# TANK PRESSURE WITH 12 FT. 1" HOSE-HOSE LINE VALVE & 1" QDC, SUBTRACT 10% FROM CHARTS IF USING 1-1/4" QDC

MULTIPLIER FOR DIFFERENT TANK PRESSURES

PRESSURE	MULTIPLIER		PRESSURE	MULTIPLIER
50	1.25		100	1.00
60	1.20	LBS. N X 1.22 = LBS. NH3	110	0.97
70	1.15		120	0.95
80	1.10	LBS. NH3 X .82 = LBS. NITROGEN	130	0.93
90	1.05		140	0.92

FORMULA FOR CHART #N X SWATH FT. X MPH X .1212 = # NITROGEN PER HOUR AT 100# TANK PRESSURE

EXAMPLE: 100 X 30 X 5 X .1212 = 1818# NITROGEN PER HOUR AT 100# TANK PRESSURE



# CONTINENTAL PRODUCTS CO., INC.

C-2500 **RED**

C-4100 **RED & BLUE**

B-9500 **RED, BLUE & WHITE**

LBS. NITROGEN PER ACRE

(INCH) 270 SWATH 22.5 FT.

SPEED @ 100 LBS. TANK PRESSURE - USE DIAL MULTIPLIER FOR PRESSURES ABOVE AND BELOW 100 LBS.

MPH 40 50 60 75 80 100 120 140 150 160 180 200 220 240 250 260 280

3.0	327	409	491	614	654	818	982	1145	1227	1309	1473	1636	1800	1963	2045	2127	2291
3.5	382	477	573	716	764	954	1145	1336	1432	1527	1718	1909	2100	2291	2386	2482	2672
4.0	436	545	654	818	873	1091	1309	1527	1636	1745	1963	2182	2400	2618	2727	2836	3054
4.5	491	614	736	920	982	1227	1473	1718	1841	1963	2209	2454	2700	2945	3068	3191	3436
5.0	545	682	818	1023	1091	1364	1636	1909	2045	2182	2454	2727	3000	3272	3409	3545	3818
5.5	600	750	900	1125	1200	1500	1800	2100	2250	2400	2700	3000	3300	3600	3750	3900	4200
6.0	654	818	982	1227	1309	1636	1963	2291	2454	2618	2945	3272	3600	3927	4091	4254	4581
6.5	709	886	1064	1329	1418	1773	2127	2482	2659	2836	3191	3545	3900	4254	4431	4609	4963
7.0	764	954	1145	1432	1527	1909	2291	2672	2863	3054	3436	3818	4200	4581	4772	4963	5345
7.5	818	1023	1227	1534	1636	2045	2454	2863	3068	3272	3681	4091	4500	4909	5113	5318	5727
8.0	873	1091	1309	1636	1745	2182	2618	3054	3272	3491	3927	4363	4800	5236	5454	5672	6108

LBS. NITROGEN PER ACRE

(INCH) 288 SWATH 24 FT.

SPEED @ 100 LBS. TANK PRESSURE - USE DIAL MULTIPLIER FOR PRESSURES ABOVE AND BELOW 100 LBS.

MPH 40 50 60 75 80 100 120 140 150 160 180 200 220 240 250 260 280

3.0	349	436	524	654	698	873	1047	1222	1309	1396	1571	1745	1920	2094	2182	2269	2443
3.5	407	509	611	764	814	1018	1222	1425	1527	1629	1833	2036	2240	2443	2545	2647	2851
4.0	465	582	698	873	931	1164	1396	1629	1745	1862	2094	2327	2560	2792	2909	3025	3258
4.5	524	654	785	982	1047	1309	1571	1833	1963	2094	2356	2618	2880	3142	3272	3403	3665
5.0	582	727	873	1091	1164	1454	1745	2036	2182	2327	2618	2909	3200	3491	3636	3781	4072
5.5	640	800	960	1200	1280	1600	1920	2240	2400	2560	2880	3200	3520	3840	4000	4160	4480
6.0	698	873	1047	1309	1396	1745	2094	2443	2618	2792	3142	3491	3840	4189	4363	4538	4887
6.5	756	945	1134	1418	1513	1891	2269	2647	2836	3025	3403	3781	4160	4538	4727	4916	5294
7.0	814	1018	1222	1527	1629	2036	2443	2851	3054	3258	3665	4072	4480	4887	5090	5294	5701
7.5	873	1091	1309	1636	1745	2182	2618	3054	3272	3491	3927	4363	4800	5236	5454	5672	6108
8.0	931	1164	1396	1745	1862	2327	2792	3258	3491	3723	4189	4654	5119	5585	5818	6050	6516

ALL METERS ARE CALIBRATED WITH CONTINENTAL FITTINGS AT 100# TANK PRESSURE WITH 12 FT. 1" HOSE-HOSE LINE VALVE & 1" QDC, SUBTRACT 10% FROM CHARTS IF USING 1-1/4" QDC

MULTIPLIER FOR DIFFERENT TANK PRESSURES

PRESSURE	MULTIPLIER		PRESSURE	MULTIPLIER
50	1.25		100	1.00
60	1.20	LBS. N X 1.22 = LBS. NH3	110	0.97
70	1.15		120	0.95
80	1.10	LBS. NH3 X .82 = LBS. NITROGEN	130	0.93
90	1.05		140	0.92

FORMULA FOR CHART #N X SWATH FT. X MPH X .1212 = # NITROGEN PER HOUR AT 100# TANK PRESSURE

EXAMPLE: 100 X 30 X 5 X .1212 = 1818# NITROGEN PER HOUR AT 100# TANK PRESSURE

# CONTINENTAL PRODUCTS CO., INC.

C-2500 **RED**

C-4100 **RED & BLUE**

B-9500 **RED, BLUE & WHITE**

LBS. NITROGEN PER ACRE

(INCH) 360 SWATH 30 FT.

SPEED @ 100 LBS. TANK PRESSURE - USE DIAL MULTIPLIER FOR PRESSURES ABOVE AND BELOW 100 LBS.

MPH	40	50	60	75	80	100	120	140	150	160	180	200	220	240	250	260	280
3.0	436	545	654	818	873	1091	1309	1527	1636	1745	1963	2182	2400	2618	2727	2836	3054
3.5	509	636	764	954	1018	1273	1527	1782	1909	2036	2291	2545	2800	3054	3182	3309	3563
4.0	582	727	873	1091	1164	1454	1745	2036	2182	2327	2618	2909	3200	3491	3636	3781	4072
4.5	654	818	982	1227	1309	1636	1963	2291	2454	2618	2945	3272	3600	3927	4091	4254	4581
5.0	727	909	1091	1364	1454	1818	2182	2545	2727	2909	3272	3636	4000	4363	4545	4727	5090
5.5	800	1000	1200	1500	1600	2000	2400	2800	3000	3200	3600	4000	4400	4800	5000	5199	5599
6.0	873	1091	1309	1636	1745	2182	2618	3054	3272	3491	3927	4363	4800	5236	5454	5672	6108
6.5	945	1182	1418	1773	1891	2363	2836	3309	3545	3781	4254	4727	5199	5672	5909	6145	-
7.0	1018	1273	1527	1909	2036	2545	3054	3563	3818	4072	4581	5090	5599	6108	6363	-	-
7.5	1091	1364	1636	2045	2182	2727	3272	3818	4091	4363	4909	5454	5999	-	-	-	-
8.0	1164	1454	1745	2182	2327	2909	3491	4072	4363	4654	5236	5818	6399	-	-	-	-

LBS. NITROGEN PER ACRE

(INCH) 396 SWATH 33 FT.

SPEED @ 100 LBS. TANK PRESSURE - USE DIAL MULTIPLIER FOR PRESSURES ABOVE AND BELOW 100 LBS.

MPH	40	50	60	75	80	100	120	140	150	160	180	200	220	240	250	260	280
3.0	480	600	720	900	960	1200	1440	1680	1800	1920	2160	2400	2640	2880	3000	3120	3360
3.5	560	700	840	1050	1120	1400	1680	1960	2100	2240	2520	2800	3080	3360	3500	3640	3920
4.0	640	800	960	1200	1280	1600	1920	2240	2400	2560	2880	3200	3520	3840	4000	4160	4480
4.5	720	900	1080	1350	1440	1800	2160	2520	2700	2880	3240	3600	3960	4320	4500	4680	5039
5.0	800	1000	1200	1500	1600	2000	2400	2800	3000	3200	3600	4000	4400	4800	5000	5199	5599
5.5	880	1100	1320	1650	1760	2200	2640	3080	3300	3520	3960	4400	4840	5279	5499	5719	6159
6.0	960	1200	1440	1800	1920	2400	2880	3360	3600	3840	4320	4800	5279	5759	5999	6239	
6.5	1040	1300	1560	1950	2080	2600	3120	3640	3900	4160	4680	5199	5719	6239	6499		
7.0	1120	1400	1680	2100	2240	2800	3360	3920	4200	4480	5039	5599	6159				
7.5	1200	1500	1800	2250	2400	3000	3600	4200	4500	4800	5399	5999					
8.0	1280	1600	1920	2400	2560	3200	3840	4480	4800	5119	5759	6399					

ALL METERS ARE CALIBRATED WITH CONTINENTAL FITTINGS AT 100# TANK PRESSURE WITH 12 FT. 1" HOSE-HOSE LINE VALVE & 1" QDC; SUBTRACT 10% FROM CHARTS IF USING 1-1/4" QDC

MULTIPLIER FOR DIFFERENT TANK PRESSURES

PRESSURE	MULTIPLIER		PRESSURE	MULTIPLIER
50	1.25		100	1.00
60	1.20	LBS. N X 1.22 = LBS. NH3	110	0.97
70	1.15		120	0.95
80	1.10	LBS. NH3 X .82 = LBS. NITROGEN	130	0.93
90	1.05		140	0.92

FORMULA FOR CHART #N X SWATH FT. X MPH X .1212 = # NITROGEN PER HOUR AT 100# TANK PRESSURE

EXAMPLE: 100 X 30 X 5 X .1212 = 1818# NITROGEN PER HOUR AT 100# TANK PRESSURE

# CONTINENTAL PRODUCTS CO., INC.

C-2500 **RED**

C-4100 **RED & BLUE**

B-9500 **RED, BLUE & WHITE**

LBS. NITROGEN PER ACRE

(INCH) 324 SWATH 27 FT.

SPEED @ 100 LBS. TANK PRESSURE - USE DIAL MULTIPLIER FOR PRESSURES ABOVE AND BELOW 100 LBS.

MPH 40 50 60 75 80 100 120 140 150 160 180 200 220 240 250 260 280

3.0	393	491	589	736	785	982	1178	1374	1473	1571	1767	1963	2160	2356	2454	2552	2749
3.5	458	573	687	859	916	1145	1374	1603	1718	1833	2062	2291	2520	2749	2863	2978	3207
4.0	524	654	785	982	1047	1309	1571	1833	1963	2094	2356	2618	2880	3142	3272	3403	3665
4.5	589	736	884	1104	1178	1473	1767	2062	2209	2356	2651	2945	3240	3534	3681	3829	4123
5.0	654	818	982	1227	1309	1636	1963	2291	2454	2618	2945	3272	3600	3927	4091	4254	4581
5.5	720	900	1080	1350	1440	1800	2160	2520	2700	2880	3240	3600	3960	4320	4500	4680	5039
6.0	785	982	1178	1473	1571	1963	2356	2749	2945	3142	3534	3927	4320	4712	4909	5105	5498
6.5	851	1064	1276	1595	1702	2127	2552	2978	3191	3403	3829	4254	4680	5105	5318	5530	5956
7.0	916	1145	1374	1718	1833	2291	2749	3207	3436	3665	4123	4581	5039	5498	5727	5956	6414
7.5	982	1227	1473	1841	1963	2454	2945	3436	3681	3927	4418	4909	5399	5890	6136	6381	-
8.0	1047	1309	1571	1963	2094	2618	3142	3665	3927	4189	4712	5236	5759	6283	-	-	-

LBS. NITROGEN PER ACRE

(INCH) 330 SWATH 27.5 FT.

SPEED @ 100 LBS. TANK PRESSURE - USE DIAL MULTIPLIER FOR PRESSURES ABOVE AND BELOW 100 LBS.

MPH 40 50 60 75 80 100 120 140 150 160 180 200 220 240 250 260 280

3.0	400	500	600	750	800	1000	1200	1400	1500	1600	1800	2000	2200	2400	2500	2600	2800
3.5	467	583	700	875	933	1167	1400	1633	1750	1866	2100	2333	2566	2800	2916	3033	3266
4.0	533	667	800	1000	1067	1333	1600	1866	2000	2133	2400	2666	2933	3200	3333	3466	3733
4.5	600	750	900	1125	1200	1500	1800	2100	2250	2400	2700	3000	3300	3600	3750	3900	4200
5.0	667	833	1000	1250	1333	1667	2000	2333	2500	2666	3000	3333	3666	4000	4166	4333	4666
5.5	733	917	1100	1375	1467	1833	2200	2566	2750	2933	3300	3666	4033	4400	4583	4766	5133
6.0	800	1000	1200	1500	1600	2000	2400	2800	3000	3200	3600	4000	4400	4800	5000	5199	5599
6.5	867	1083	1300	1625	1733	2166	2600	3033	3250	3466	3900	4333	4766	5199	5416	5633	6066
7.0	933	1167	1400	1750	1866	2333	2800	3266	3500	3733	4200	4666	5133	5599	5833	6066	-
7.5	1000	1250	1500	1875	2000	2500	3000	3500	3750	4000	4500	5000	5499	5999	6249	6499	-
8.0	1067	1333	1600	2000	2133	2666	3200	3733	4000	4266	4800	5333	5866	6399	-	-	-

ALL METERS ARE CALIBRATED WITH CONTINENTAL FITTINGS AT 100# TANK PRESSURE WITH 12 FT. 1" HOSE-HOSE LINE VALVE & 1" QDC; SUBTRACT 10% FROM CHARTS IF USING 1-1/4" QDC

MULTIPLIER FOR DIFFERENT TANK PRESSURES

PRESSURE	MULTIPLIER		PRESSURE	MULTIPLIER
50	1.25		100	1.00
60	1.20	LBS. N X 1.22 = LBS. NH3	110	0.97
70	1.15		120	0.95
80	1.10	LBS. NH3 X .82 = LBS. NITROGEN	130	0.93
90	1.05		140	0.92

FORMULA FOR CHART #N X SWATH FT. X MPH X .1212 = # NITROGEN PER HOUR AT 100# TANK PRESSURE

EXAMPLE: 100 X 30 X 5 X .1212 = 1818# NITROGEN PER HOUR AT 100# TANK PRESSURE

# CONTINENTAL PRODUCTS CO., INC.

C-2500 **RED**

C-4100 **RED & BLUE**

B-9500 **RED, BLUE & WHITE**

LBS. NITROGEN PER ACRE

(INCH) 480 SWATH 40 FT.

SPEED @ 100 LBS. TANK PRESSURE - USE DIAL MULTIPLIER FOR PRESSURES ABOVE AND BELOW 100 LBS.  
MPH 40 50 60 75 80 100 120 140 150 160 180 200 220 240 250 260 280

3.0	582	727	873	1091	1164	1454	1745	2036	2182	2327	2618	2909	3200	3491	3636	3781	4072
3.5	679	848	1018	1273	1357	1697	2036	2376	2545	2715	3054	3394	3733	4072	4242	4412	4751
4.0	776	970	1164	1454	1551	1939	2327	2715	2909	3103	3491	3878	4266	4654	4848	5042	5430
4.5	873	1091	1309	1636	1745	2182	2618	3054	3272	3491	3927	4363	4800	5236	5454	5672	6108
5.0	970	1212	1454	1818	1939	2424	2909	3394	3636	3878	4363	4848	5333	5818	6060	6302	-
5.5	1067	1333	1600	2000	2133	2666	3200	3733	4000	4266	4800	5333	5866	6399	-	-	-
6.0	1164	1454	1745	2182	2327	2909	3491	4072	4363	4654	5236	5818	6399	-	-	-	-
6.5	1260	1576	1891	2363	2521	3151	3781	4412	4727	5042	5672	6302	-	-	-	-	-
7.0	1357	1697	2036	2545	2715	3394	4072	4751	5090	5430	6108	-	-	-	-	-	-
7.5	1454	1818	2182	2727	2909	3636	4363	5090	5454	5818	-	-	-	-	-	-	-
8.0	1551	1939	2327	2909	3103	3878	4654	5430	5818	6205	-	-	-	-	-	-	-

LBS. NITROGEN PER ACRE

(INCH) 510 SWATH 42.5 FT.

SPEED @ 100 LBS. TANK PRESSURE - USE DIAL MULTIPLIER FOR PRESSURES ABOVE AND BELOW 100 LBS.  
MPH 40 50 60 75 80 100 120 140 150 160 180 200 220 240 250 260 280

3.0	618	773	927	1159	1236	1545	1854	2163	2318	2472	2782	3091	3400	3709	3863	4018	4327
3.5	721	901	1082	1352	1442	1803	2163	2524	2704	2885	3245	3606	3966	4327	4507	4687	5048
4.0	824	1030	1236	1545	1648	2060	2472	2885	3091	3297	3709	4121	4533	4945	5151	5357	5769
4.5	927	1159	1391	1738	1854	2318	2782	3245	3477	3709	4172	4636	5099	5563	5795	6027	6490
5.0	1030	1288	1545	1932	2060	2576	3091	3606	3863	4121	4636	5151	5666	6181	6439	-	-
5.5	1133	1417	1700	2125	2266	2833	3400	3966	4250	4533	5099	5666	6233	-	-	-	-
6.0	1236	1545	1854	2318	2472	3091	3709	4327	4636	4945	5563	6181	-	-	-	-	-
6.5	1339	1674	2009	2511	2679	3348	4018	4687	5022	5357	6027	-	-	-	-	-	-
7.0	1442	1803	2163	2704	2885	3606	4327	5048	5409	5769	6490	-	-	-	-	-	-
7.5	1545	1932	2318	2897	3091	3863	4636	5409	5795	6181	-	-	-	-	-	-	-
8.0	1648	2060	2472	3091	3297	4121	4945	5769	6181	6593	-	-	-	-	-	-	-

ALL METERS ARE CALIBRATED WITH CONTINENTAL FITTINGS AT 100# TANK PRESSURE WITH 12 FT. 1" HOSE-HOSE LINE VALVE & 1" QDC, SUBTRACT 10% FROM CHARTS IF USING 1-1/4" QDC

### MULTIPLIER FOR DIFFERENT TANK PRESSURES

PRESSURE	MULTIPLIER		PRESSURE	MULTIPLIER
50	1.25		100	1.00
60	1.20	LBS. N X 1.22 = LBS. NH3	110	0.97
70	1.15		120	0.95
80	1.10	LBS. NH3 X .82 = LBS. NITROGEN	130	0.93
90	1.05		140	0.92

FORMULA FOR CHART #N X SWATH FT. X MPH X .1212 = # NITROGEN PER HOUR AT 100# TANK PRESSURE

EXAMPLE: 100 X 30 X 5 X .1212 = 1818# NITROGEN PER HOUR AT 100# TANK PRESSURE

# CONTINENTAL PRODUCTS CO., INC.

C-2500 **RED**

C-4100 **RED & BLUE**

B-9500 **RED, BLUE & WHITE**

LBS. NITROGEN PER ACRE

(INCH) 420 SWATH 35 FT.

SPEED @ 100 LBS. TANK PRESSURE - USE DIAL MULTIPLIER FOR PRESSURES ABOVE AND BELOW 100 LBS.  
MPH 40 50 60 75 80 100 120 140 150 160 180 200 220 240 250 260 280

3.0	509	636	764	954	1018	1273	1527	1782	1909	2036	2291	2545	2800	3054	3182	3309	3563
3.5	594	742	891	1114	1188	1485	1782	2079	2227	2376	2672	2969	3266	3563	3712	3860	4157
4.0	679	848	1018	1273	1357	1697	2036	2376	2545	2715	3054	3394	3733	4072	4242	4412	4751
4.5	764	954	1145	1432	1527	1909	2291	2672	2863	3054	3436	3818	4200	4581	4772	4963	5345
5.0	848	1061	1273	1591	1697	2121	2545	2969	3182	3394	3818	4242	4666	5090	5303	5515	5939
5.5	933	1167	1400	1750	1866	2333	2800	3266	3500	3733	4200	4666	5133	5599	5833	6066	-
6.0	1018	1273	1527	1909	2036	2545	3054	3563	3818	4072	4581	5090	5599	6108	6363	-	-
6.5	1103	1379	1654	2068	2206	2757	3309	3860	4136	4412	4963	5515	6066	-	-	-	-
7.0	1188	1485	1782	2227	2376	2969	3563	4157	4454	4751	5345	5939	-	-	-	-	-
7.5	1273	1591	1909	2386	2545	3182	3818	4454	4772	5090	5727	6363	-	-	-	-	-
8.0	1357	1697	2036	2545	2715	3394	4072	4751	5090	5430	6108	-	-	-	-	-	-

LBS. NITROGEN PER ACRE

(INCH) 432 SWATH 36 FT.

SPEED @ 100 LBS. TANK PRESSURE - USE DIAL MULTIPLIER FOR PRESSURES ABOVE AND BELOW 100 LBS.  
MPH 40 50 60 75 80 100 120 140 150 160 180 200 220 240 250 260 280

3.0	524	654	785	982	1047	1309	1571	1833	1963	2094	2356	2618	2880	3142	3272	3403	3665
3.5	611	764	916	1145	1222	1527	1833	2138	2291	2443	2749	3054	3360	3665	3818	3971	4276
4.0	698	873	1047	1309	1396	1745	2094	2443	2618	2792	3142	3491	3840	4189	4363	4538	4887
4.5	785	982	1178	1473	1571	1963	2356	2749	2945	3142	3534	3927	4320	4712	4909	5105	5498
5.0	873	1091	1309	1636	1745	2182	2618	3054	3272	3491	3927	4363	4800	5236	5454	5672	6108
5.5	960	1200	1440	1800	1920	2400	2880	3360	3600	3840	4320	4800	5279	5759	5999	6239	-
6.0	1047	1309	1571	1963	2094	2618	3142	3665	3927	4189	4712	5236	5759	6283	-	-	-
6.5	1134	1418	1702	2127	2269	2836	3403	3971	4254	4538	5105	5672	6239	-	-	-	-
7.0	1222	1527	1833	2291	2443	3054	3665	4276	4581	4887	5498	6108	-	-	-	-	-
7.5	1309	1636	1963	2454	2618	3272	3927	4581	4909	5236	5890	-	-	-	-	-	-
8.0	1396	1745	2094	2618	2792	3491	4189	4887	5236	5585	6283	-	-	-	-	-	-

ALL METERS ARE CALIBRATED WITH CONTINENTAL FITTINGS AT 100# TANK PRESSURE WITH 12 FT. 1" HOSE-HOSE LINE VALVE & 1" QDC, SUBTRACT 10% FROM CHARTS IF USING 1-1/4" QDC

MULTIPLIER FOR DIFFERENT TANK PRESSURES

PRESSURE	MULTIPLIER		PRESSURE	MULTIPLIER
50	1.25		100	1.00
60	1.20	LBS. N X 1.22 = LBS. NH3	110	0.97
70	1.15		120	0.95
80	1.10	LBS. NH3 X .82 = LBS. NITROGEN	130	0.93
90	1.05		140	0.92

FORMULA FOR CHART #N X SWATH FT. X MPH X .1212 = # NITROGEN PER HOUR AT 100# TANK PRESSURE

EXAMPLE: 100 X 30 X 5 X .1212 = 1818# NITROGEN PER HOUR AT 100# TANK PRESSURE

# CONTINENTAL PRODUCTS CO., INC.

C-2500 **RED**

C-4100 **RED & BLUE**

B-9500 **RED, BLUE & WHITE**

LBS. NITROGEN PER ACRE

(INCH) 540 SWATH 45 FT.

SPEED @ 100 LBS. TANK PRESSURE - USE DIAL MULTIPLIER FOR PRESSURES ABOVE AND BELOW 100 LBS.  
MPH 40 50 60 75 80 100 120 140 150 160 180 200 220 240 250 260 280

3.0	654	818	982	1227	1309	1636	1963	2291	2454	2618	2945	3272	3600	3927	4091	4254	4581
3.5	764	954	1145	1432	1527	1909	2291	2672	2863	3054	3436	3818	4200	4581	4772	4963	5345
4.0	873	1091	1309	1636	1745	2182	2618	3054	3272	3491	3927	4363	4800	5236	5454	5672	6108
4.5	982	1227	1473	1841	1963	2454	2945	3436	3681	3927	4418	4909	5399	5890	6136	6381	-
5.0	1091	1364	1636	2045	2182	2727	3272	3818	4091	4363	4909	5454	5999	-	-	-	-
5.5	1200	1500	1800	2250	2400	3000	3600	4200	4500	4800	5399	5999	-	-	-	-	-
6.0	1309	1636	1963	2454	2618	3272	3927	4581	4909	5236	5890	-	-	-	-	-	-
6.5	1418	1773	2127	2659	2836	3545	4254	4963	5318	5672	6381	-	-	-	-	-	-
7.0	1527	1909	2291	2863	3054	3818	4581	5345	5727	6108	-	-	-	-	-	-	-
7.5	1636	2045	2454	3068	3272	4091	4909	5727	6136	-	-	-	-	-	-	-	-
8.0	1745	2182	2618	3272	3491	4363	5236	6108	-	-	-	-	-	-	-	-	-

LBS. NITROGEN PER ACRE

(INCH) 600 SWATH 50 FT.

SPEED @ 100 LBS. TANK PRESSURE - USE DIAL MULTIPLIER FOR PRESSURES ABOVE AND BELOW 100 LBS.  
MPH 40 50 60 75 80 100 120 140 150 160 180 200 220 240 250 260 280

3.0	727	909	1091	1364	1454	1818	2182	2545	2727	2909	3272	3636	4000	4363	4545	4727	5090
3.5	848	1061	1273	1591	1697	2121	2545	2969	3182	3394	3818	4242	4666	5090	5303	5515	5939
4.0	970	1212	1454	1818	1939	2424	2909	3394	3636	3878	4363	4848	5333	5818	6060	6302	-
4.5	1091	1364	1636	2045	2182	2727	3272	3818	4091	4363	4909	5454	5999	-	-	-	-
5.0	1212	1515	1818	2273	2424	3030	3636	4242	4545	4848	5454	6060	-	-	-	-	-
5.5	1333	1667	2000	2500	2666	3333	4000	4666	5000	5333	5999	-	-	-	-	-	-
6.0	1454	1818	2182	2727	2909	3636	4363	5090	5454	5818	-	-	-	-	-	-	-
6.5	1576	1970	2363	2954	3151	3939	4727	5515	5909	6302	-	-	-	-	-	-	-
7.0	1697	2121	2545	3182	3394	4242	5090	5939	6363	-	-	-	-	-	-	-	-
7.5	1818	2273	2727	3409	3636	4545	5454	6363	-	-	-	-	-	-	-	-	-
8.0	1939	2424	2909	3636	3878	4848	5818	-	-	-	-	-	-	-	-	-	-

ALL METERS ARE CALIBRATED WITH CONTINENTAL FITTINGS AT 100# TANK PRESSURE WITH 12 FT. 1" HOSE-HOSE LINE VALVE & 1" QDC, SUBTRACT 10% FROM CHARTS IF USING 1-1/4" QDC

MULTIPLIER FOR DIFFERENT TANK PRESSURES

PRESSURE	MULTIPLIER		PRESSURE	MULTIPLIER
50	1.25		100	1.00
60	1.20	LBS. N X 1.22 = LBS. NH3	110	0.97
70	1.15		120	0.95
80	1.10	LBS. NH3 X .82 = LBS. NITROGEN	130	0.93
90	1.05		140	0.92

FORMULA FOR CHART #N X SWATH FT. X MPH X .1212 = # NITROGEN PER HOUR AT 100# TANK PRESSURE

EXAMPLE: 100 X 30 X 5 X .1212 = 1818# NITROGEN PER HOUR AT 100# TANK PRESSURE