



FMCS-155F-HYD Series High Performance Hydraulic Motor Driven Centrifugal Pump

The Pro 5 Series has the same compact, close coupled design that you have come to expect with several new features to maximize life and reliability. E-coat corrosion protection and larger bearings provide longer life. A Severe duty silicon carbide seal resists abrasive scratching and transfers heat away from the faces for improved survival during short run-dry events. Interchangeability of parts within the Pro 5 Series simplifies stock and reduces inventory needed for field support.



SPECIFICATIONS

Pump Specifications

Ports	220 x 200 Flange and 1-1/2" x 1-1/4" PT	
Max. Flow	145 GPM (550 LPM) for 206	155 GPM (587 LPM) for 304
Max. Pressure	120 PSI (8.3 BAR) for 206	130 PSI (9.0 BAR) for 304
Construction	E-coated Cast Iron	
Seal	Silicon Carbide / FKM with O-ring Seat	
Shaft	Stainless Steel	
Bearings	Sealed for long life	
Impeller	Thermoplastic with Stainless Steel Hub	
Wear Ring	Stainless Steel	

Motor Specifications

Type	High Efficiency Close Coupled Gear Motor			
Seal	High Pressure Double Lip Teflon			
Internal Coasting Check	Prevents Damaging Pressure Spikes when Turned Off			
Size	-206	-206 PWM	-304	-304 PWM
Maximum Flow	7 GPM (26.5 LPM)		9 GPM (34 LPM)	
Maximum Pressure	2700 PSI (186 BAR)		2500 PSI (172 BAR)	
Bypass Needle	Up to 9 GPM (34 LPM)	Not included	Up to 9 GPM (34 LPM)	Not included
Use on HYD Systems	PC, LS, and OC	PC, LS	PC, LS, and OC	PC, LS
External Reverse Check	✓	✓	✓	✓
Inlet Adapter / Restrictor Body 1/2" FNPT	1/2" FNPT	#10 SAE	1/2" FNPT	#10 SAE
Restrictor Insert	✓	×	✓	×
-206 PWM	Integrated 12V Proportional Control Valve and Pressure Relief Valve for use in Precision Applications using Pulse Width Modulated control systems.			
Case Drain (Option)	Available	Not Available	Available	Not Available
Flow Limiter (Optional)	LS-204N	Do not use	LS-206N	Do not use

Available Models

FMCS-155F-HYD-206	FMCS-155F-HYD-206-PWM
FMCS-155F-HYD-304	FMCS-155F-HYD-304-PWM

PERFORMANCE

FMCS-155F-HYD-206

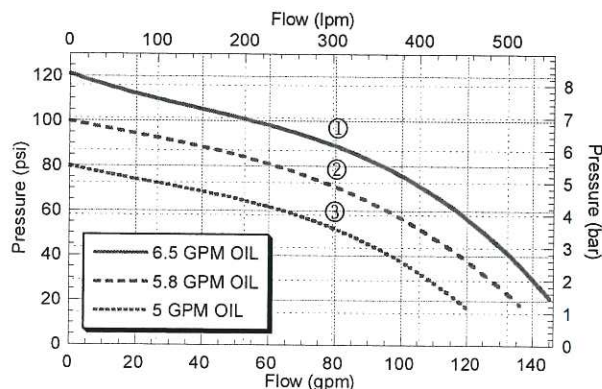

CURVE	-206	
1	6.5 GPM	24.6 LPM
2	5.8 GPM	22.0 LPM
3	5.0 GPM	19.0 LPM

FMCS-155F-HYD-304

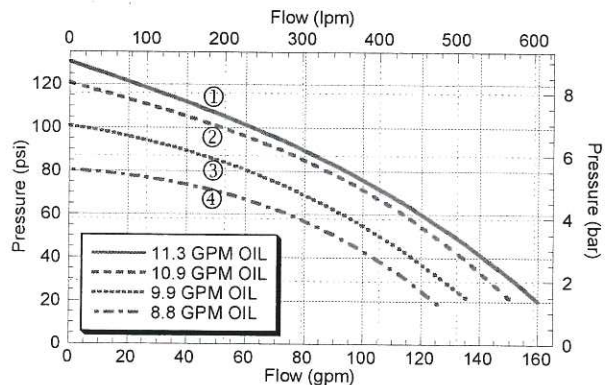

CURVE	-304	
1	11.3 GPM	42.8 LPM
2	10.9 GPM	41.3 LPM
3	9.9 GPM	37.5 LPM
4	8.8 GPM	33.3 LPM



FMCS-155F-HYD Series

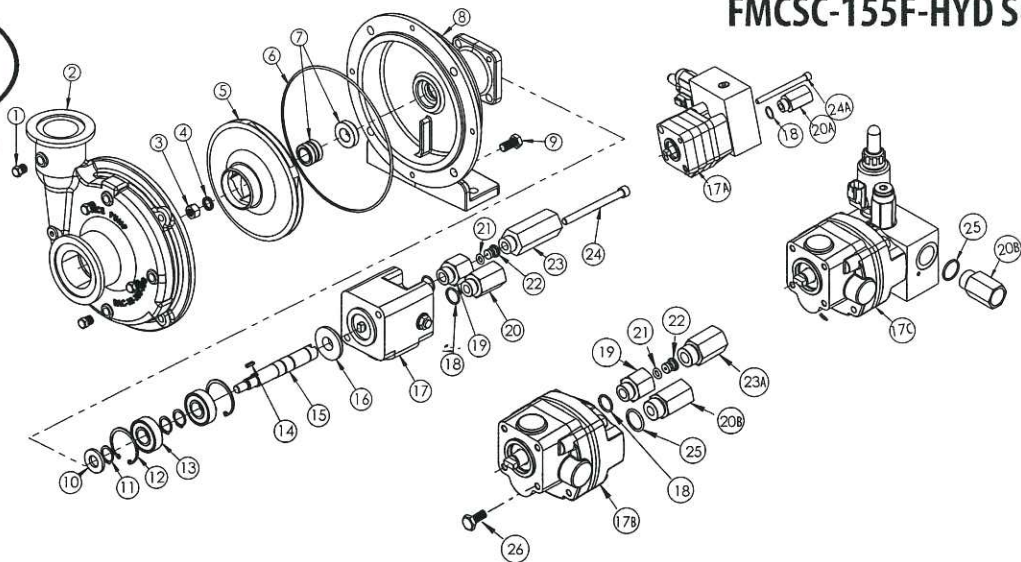

PARTS LIST

REF. #	PART NUMER	EDP #	DESCRIPTION	REQ.
1	BAC-53	41100	Pipe plug	4
1	41120	41120	Pipe plug, stainless steel (optional)	4
2	BAC-12-150-FLG-EC	40266	Volute, cast iron, NPT and flanged, e-coated	1
3	BAC-23-B-SS	40393	Nut, 3/8" NF, SS	1
4	BAC-24-B-SS	42702	Washer, 3/8" SS, vibration proof	1
5	BAC-26-150-P	40446	Impeller, thermoplastic, keyway	1
5	BAC-26-150-CI	40444	Impeller, cast iron, keyway	1
5	BAC-26-150-PI	40448	Impeller, thermoplastic, keyway	1
5	BAC-26-150-SS	40449	Impeller, stainless steel, keyway	1
6 [Ⓞ]	BAC-4-150	40015	O-ring, body seal	1
7 [Ⓞ]	BAC-75C-205V	40149	Seal, type 2106 silicon carbide mechanical seal	1
8	BAC-14-5-HYD	40288	Mounting frame, cast iron, e-coated	1
9	40950	40950	Cap screw, 3/8"NC x 3/4" hex head	4
9	40930	40930	Cap screw, 3/8"NC x 3/4" hex head, stainless steel (optional)	4
10	BAC-54	41130	Slinger	1
11	BACH-32-HD	40385	Snap ring, external, shaft	3
12	BACH-33	40820	Snap ring, internal, mounting frame	2
13	40880	40880	Bearing	2
14	BACH-25	40420	Key, 1/8" x 1/8" x 7/16" SS	1
15	BAC-6-125-HYD-SS	41582	Shaft, .625 driven with tang slot, stainless steel	1
16	S255	40177	Seal support spacer (206N)	1
16	S300	40162	Seal support spacer (304N)	1
17	BAC-75-HYD-206-PRO5	41329	Hydraulic motor, 7 GPM (includes 16)	1
17A	BAC-75-HYD-206-PRO5-PWM	41290	Hydraulic motor, integrated PWM valve, 7 GPM (includes 16, 17A, 18, 20A, 24A)	1
17B	BAC-75-HYD-304	41381	Hydraulic motor, 9 GPM (includes 16, 17B, 18, 19, 20B, 21, 22)	1
17C	BAC-75-HYD-304-PWM	41348	Hydraulic motor, integrated PWM valve, 9 GPM (includes 16, 17C, 20B, 25, 26)	1
18	41875	41875	O-ring, #8 SAE fitting	2
19	BAC-80-8SAE	41455	Body, restrictor orifice, #8 SAE x 1/2"NPT, w/ O-ring	1
20	BAC-78-8SAE	41441	Reverse check assembly, #8 SAE x 1/2"NPT, w/ O-ring	1
20A	BAC-78-10X8SAE	41462	Reverse check assembly, #8 SAE x #10 SAE, w/ O-ring	1
20B	BAC-78-10X10SAE	41467	Reverse check assembly, #10 SAE x #10 SAE, w/ O-ring	1
21	41448	41448	O-ring, restrictor	1
22	BAC-79-7	41456	Orifice insert, restrictor, w/ O-ring (206) (Do not use with 206-PWM)	1
22	BAC-79-8	41447	Orifice insert, restrictor, w/ O-ring (304) (Do not use with 304-PWM)	1
23	LS-206N	41418	Flow limiting valve, #8 MSAE x 1/2" FNPT (206) (optional)	1
23A	LS-304N	41429	Flow limiting valve, #8 MSAE x 1/2" FNPT (304) (optional)	1
24	41259	41255	Cap screw, 5/16"NC x 3-3/4" socket head, SS (for 206 motor)	2
24A	41263	41263	Cap screw, 5/16"NC x 6" socket head, SS (for 206-PWM motor)	2
25	41445	41445	O-ring, #10 SAE	1
26	41130	41130	Mounting bolt for 300 series motor	2
Ⓞ	RK-FMCS-PRO5	52717	Repair kit, includes items 6 and 7	-
*	RK-BAC-75-HYD-L	41374	Repair kit; 200 series hyd motor with high pressure lip seal	-
*	RK-BAC-75-HYD-300-L	41362	Repair kit; 300 series hyd motor with high pressure lip seal	-

* Not shown in parts diagram

DIMENSIONS

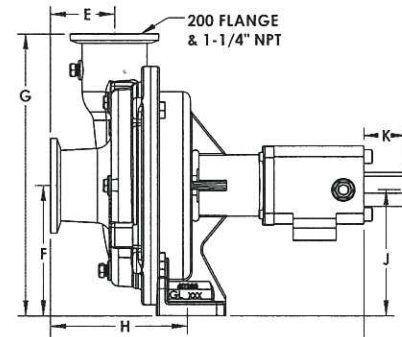
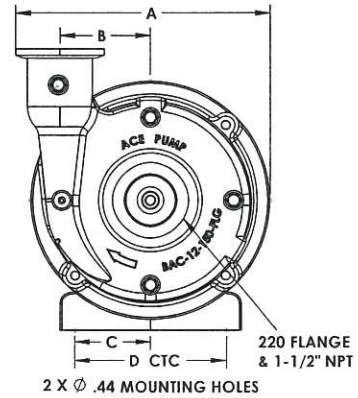

Ref.	A	B	C	D	E	F	G	H	K
Inches	10.22	3.22	2.63	5.25	2.35	3.94	8.65	4.51	1.50
MM	259.6	81.8	66.8	133.4	59.7	100.1	219.7	114.6	38.1

		-206		-206-PWM	
Ref.	I	J	I	J	
Inches	10.81	4.36	14.07	4.04	
MM	274.6	110.7	357.4	102.6	
		-304		-304-PWM	
Ref.	I	J	I	J	
Inches	12.35	3.35	13.74	4.04	
MM	313.7	85.1	349.0	102.6	

3D Model Available

<https://www.3DContentCentral.com/parts/supplier/Ace-Pumps.aspx>