

Copyright. All information furnished within this document, electronic file or design correspondence is the property of Den Hartog industries, Inc. and shall not be used, disclosed to others or copied without the expressed written consent of Den Hartog industries, Inc.

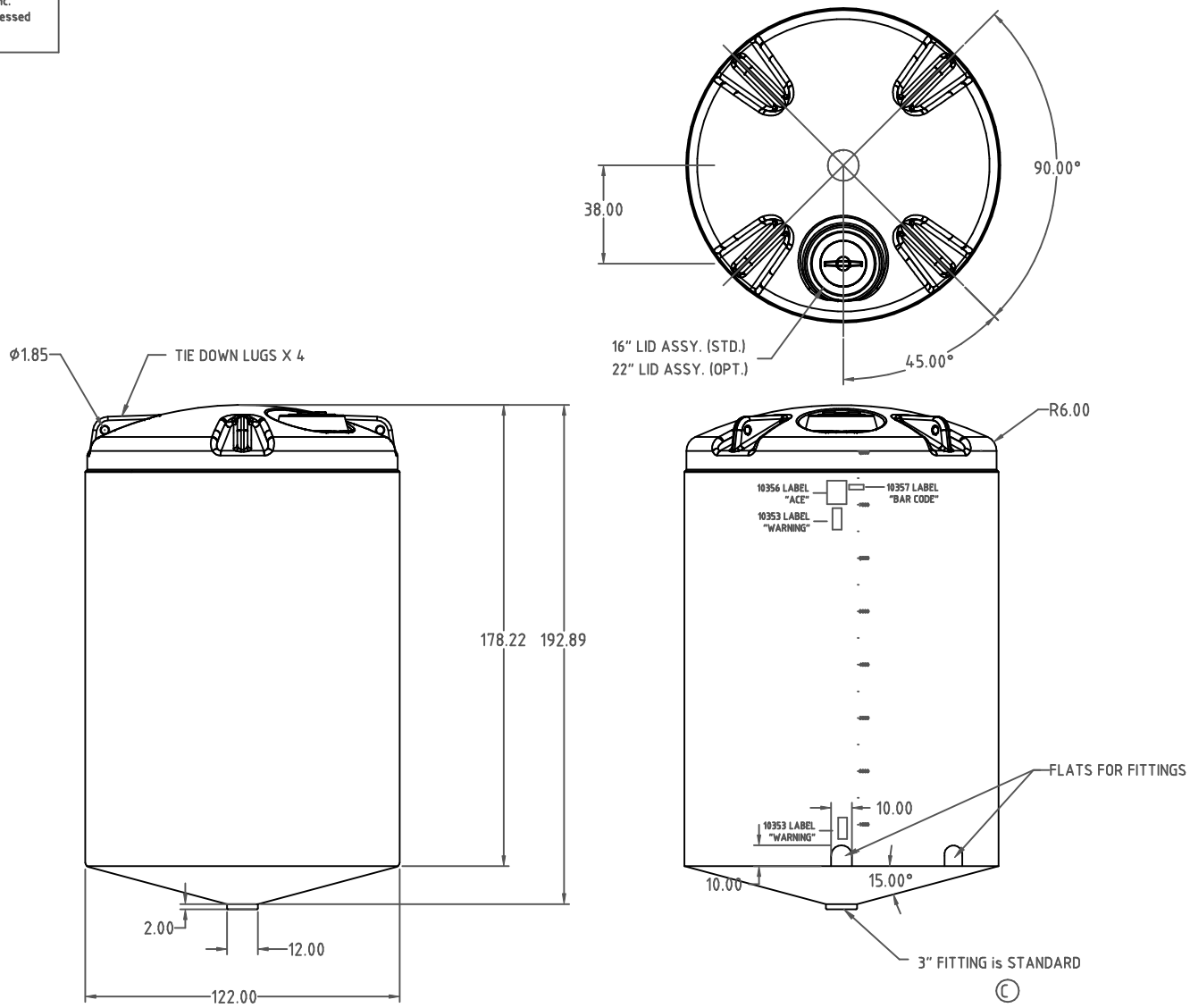

				DRAWN / DATE DHJ 1/16/07	MATERIAL 10538 2 MELT
B	CHANGED STANDARD FITTING FROM 2" TO 3"	3/31/10 DHJ	2013	APPRD. / DATE REH 4/18/07	
A	CHANGED PART NUMBER	DHJ 5/7/09			
REV	DESCRIPTION	BY / DATE	CCN		
ALL DIMENSIONS ARE IN DECIMAL INCHES TOLERANCES UNLESS OTHERWISE SPECIFIED		THIRD ANGLE PROJECTION ANSI 14.5M		SHOT WEIGHT: 2100 LBS.	NOTES: 1. WHITE, BLACK, OR YELLOW COLOR
POLYETHYLENE		METAL		SHIPPING WEIGHT: 2102 LBS.	
±1% @ 68° F		DECIMAL ± .125" FRACTION ± 1/4" ANGLE ± 1°		FINISH:	



Den Hartog
INDUSTRIES, INC.

Ace Roto-Mold Injection Molding Blow Molding Sowjoy
4010 HOSPERS DRIVE S. BOX 425, HOSPERS, IOWA 51238-0425

DESCRIPTION 8250 GALLON 15° CONE BOTTOM TANK	
SCALE N.S.	PART NO. CB8250-122