



# High Capacity Hydraulic Driven Centrifugal Pump



## FMC-200-HYD-210

- Suction 2" Discharge 1-1/2"
- Recommended for use on the following Hydraulic Systems:
  - ✓ Pressure Compensating Closed Center
  - ✓ Load Sensing or Pressure Flow Compensating Closed Center
  - ✓ Open Center from 8 to 17 GPM
- 8 GPM Hydraulic Motor - Maximum Hydraulic Pressure 1700 PSI
- Integral Needle Valve bypasses up to 9 GPM on Open Center Systems
- Standard Viton® Carbon/Ceramic seal or Optional Severe Duty Silicon Carbide Mechanical Seal
- Stainless Steel Shaft and Wear Ring

Valox® is a registered trademark of GE Plastics.  
 Viton® is a registered trademark of DuPont Dow Elastomers.

### PERFORMANCE CHART

SHUT-OFF 0 GPM	60 GPM	90 GPM	120 GPM	150 GPM	180 GPM
80 PSI	77 PSI	74 PSI	68 PSI	58 PSI	51 PSI
60 PSI	56 PSI	53 PSI	47 PSI	40 PSI	-
40 PSI	39 PSI	34 PSI	29 PSI	-	-

Use the SHUT-OFF pressure of your spraying system to determine which line of data applies. The hydraulic system input pressure and flow will vary within the chart. Contact factory for more data.

**MAXIMUM SHUT-OFF PRESSURE - 80 PSI**

### DIMENSIONS

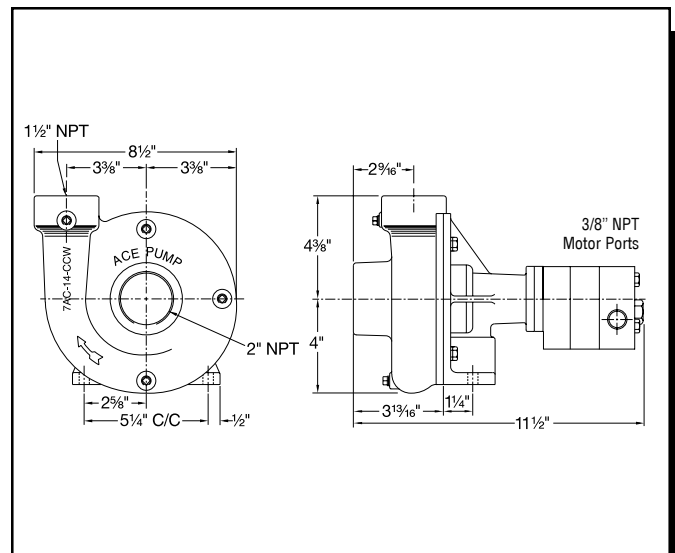



# FMC-200-HYD-210

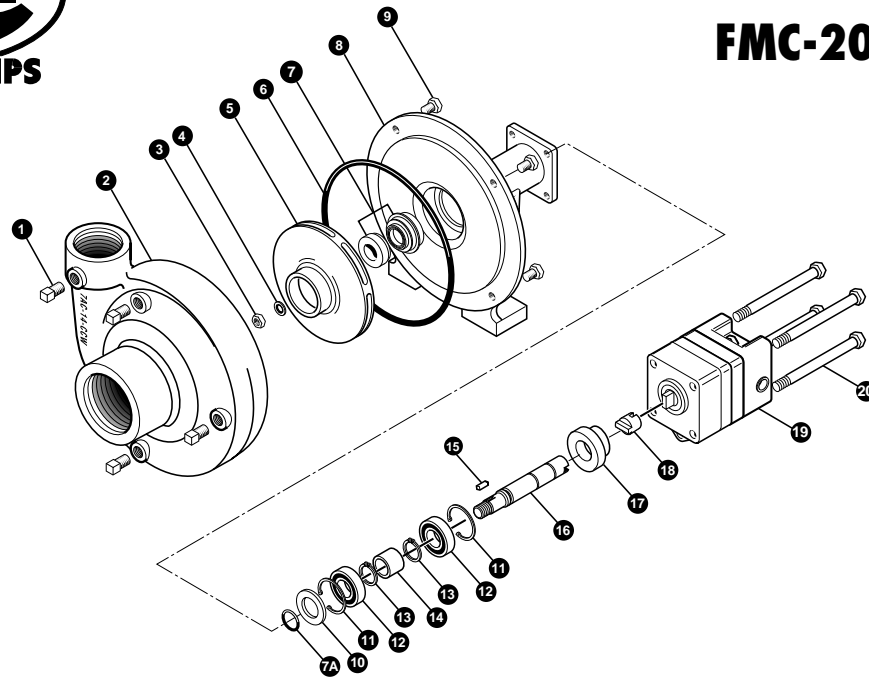

REF. #	PART NUMBER	EDP #	DESCRIPTION	REQ.
1	BAC-53	41110	Pipe plug	4
1	41120	41120	Pipe plug, stainless steel (optional)	4
2	7AC-14-CCW	41526	Volute, 2" x 1-1/2"	1
3	BAC-23-A	40391	Nut, 3/8" NF, cad plated	1
4	BAC-24-HYD-SS	40400	Washer, 3/8" star, stainless steel	1
5	BAC-26-200-CI	40433	Impeller, with extended keyway, cast iron (serial E-9 and up)	1
5	BAC-26-200-P	40434	Impeller, with extended keyway, Valox plastic (available 12/99)	1
5	BAC-26-HYD-200-CI	41525	Impeller, cast iron, keyway (obsolete 6/1/99)	1
*6	BAC-4	40010	Gasket, 4 hole	1
*6	BAC-4A	40005	O-ring, body seal, effective April 1996	1
*7	BAC-7V	40151	Seal, mechanical, Viton (includes 40160 O-Ring)	1
7	BAC-7SC	40152	Seal, mechanical, silicon carbide (includes 40160 O-Ring) (optional)	1
7A	40160	40160	O-ring, shaft seal	1
8	BAC-14-HYD	40300	Mounting frame	1
9	40950	40950	Cap screw, 3/8" NC x 3/4" hex head	4
9	40930	40930	Cap screw, 3/8" NC x 3/4" hex head, stainless steel (optional)	4
10	BAC-54	41130	Slinger	1
11	BAC-33	40810	Snap ring, internal, BAC-14 mounting frame	2
12	BAC-37	40870	Ball Bearing, sealed, BAC-6 shaft	2
13	BAC-32	40790	Snap ring, external, BAC-6 shaft	2
14	BAC-32-S	40795	Spacer for BAC-6 shaft	1
15	BAC-25	40425	Key, 1/8" x 1/8" x 13/16", extended keyway (serial E-9 and up)	1
15	BACH-25	40420	Key, 1/8" x 1/8" x 1/2" (obsolete 6/99)	1
16	BAC-6-HYD-200-SS	40063	Shaft, extended keyway, tang slot, stainless steel (serial E-9 and up)	1
16	BAC-6-HYD-SS	40061	Shaft, 5/8" dia., keyway, tang slot, stainless steel (obsolete 6/99)	1
17	S200	40161	Seal support spacer for 200 Series HYD motor, effective 6/00	1
18	BAC-76-HYD	41380	Coupling for hydraulic motor	1
19	BAC-75-HYD-210	41375	Hydraulic motor, 8 GPM	1
20	41257	41257	Cap screw, 5/16" N. C. x 4" hex head, motor to pump	4
#	RK-FMC	52700	Repair kit for FMC series pump	-
#	RK-BAC-75-HYD	41371	Repair kit for 200 Series hydraulic motor	-
#	RK-BAC-75-HYD-L	41362	Repair kit for 200 Series -L hydraulic motor (effective 10/1/99)	-

\* Items included in pump repair kit.

**Ace Pump Corporation • P.O. Box 13187 - 1650 Channel Avenue • Memphis, TN 38113**  
**www.AcePumps.com • Phone: 901-948-8514 • Fax: 901-774-6147**

Ace Form # FMC-200-HYD-210  
 Revised 04/01